

MODEL B ELECTRIC HYDRAULIC PUMP

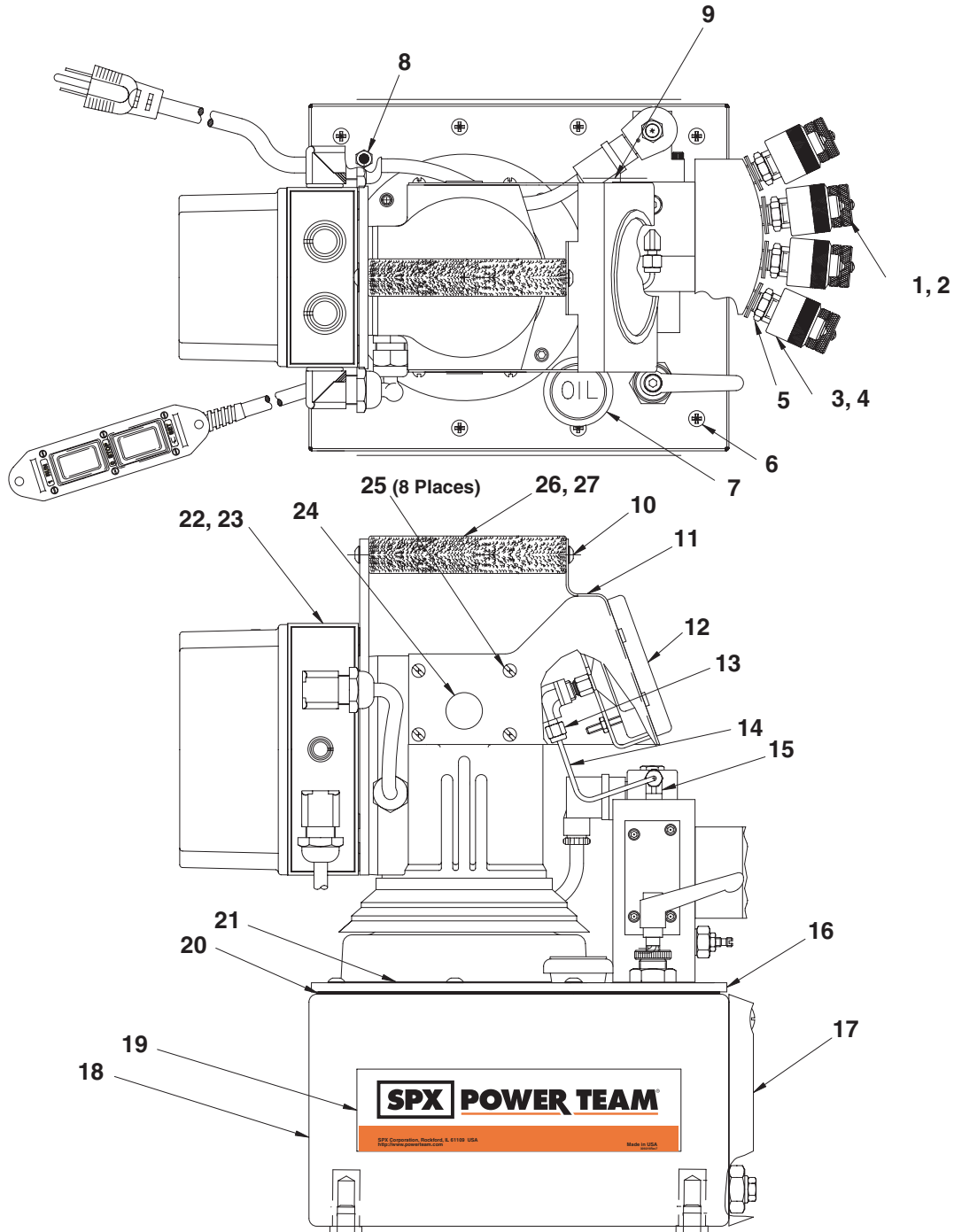

Parts List, Form No. 1000049, Back sheet 1 of 7

Item No.	Part No.	No. Req'd	Description
1	*251410	4	Quick Coupler
2	*252364	4	Dust Plug
3	*251411	4	Quick Plug Coupler
4	*252365	4	Dust Cap
5	*10672	4	Straight Fitting
6	10177	10	Screw, Round Hd (1/4-20 x 3/4)
7	*350925	1	Filler Cap
8	251599	1	Vent, Breather Filter
9	215164	1	Decal, Specifications
10	251437	2	Screw, Button Hd (1/4-20 x 1/2)
11	58884WH2	1	Bracket, Gauge
12	252426	1	Gauge (10,000 psi 4" Diameter)
13	253160	1	90° Elbow Fitting
14	2000208	1	Tube, Oil Line
15	253159	1	90° Elbow Fitting
16	3000118	1	Cover Plate Assembly
17	17586	1	Sight Gauge (1-1/2")
18	65599OR9	1	Reservoir (2 gal.)
19	309219	2	Decal, (Tradename Power Team)
20	40164	1	Gasket, Reservoir
21	30650	1	Gasket, Motor Base
22	3000117	1	Assembly, Motor Control
23	21091	1	Coupling
24	19502	2	Plug, Hole
25	11539	8	Screw, Round Hd (10-24 x 1/4)
26	252154	1	Handle
27	251600	1	Grip, Handle

Part numbers marked with an asterisk (*) are included with
3000113 Valve Assembly

GENERAL PUMP SIDE VIEW

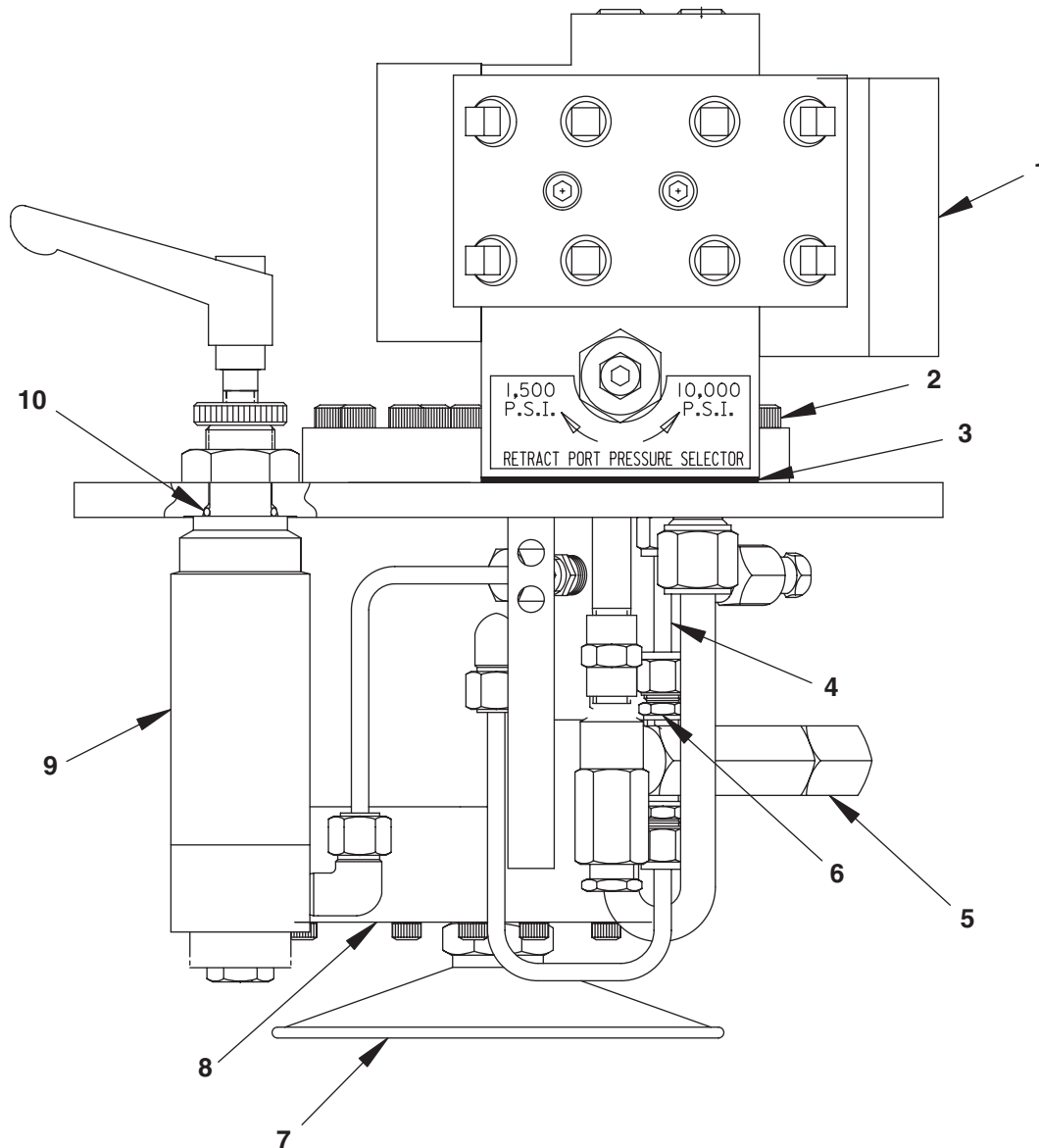

Item No.	Part No.	No. Req'd	Description
1	3000113	1	Valve, Solenoid (4 Way Open Ctr)
2	10016	3	Screw, Socket Hd (1/4-20 x 1)
3	351095	1	Gasket, Valve
4	360029	1	Tube, Oil Line
5	21943	1	Accumulator

Item No.	Part No.	No. Req'd	Description
6	14844	4	Fitting, Straight (1/8 NPTF)
7	21344	1	Screen, Filter
8	41064-2	1	Pump, Basic
9	421429	1	Regulator, Pressure
10	10527	1	O-Ring (Nitrile .37 x .25)

GENERAL PUMP BOTTOM VIEW & SECTION A-A

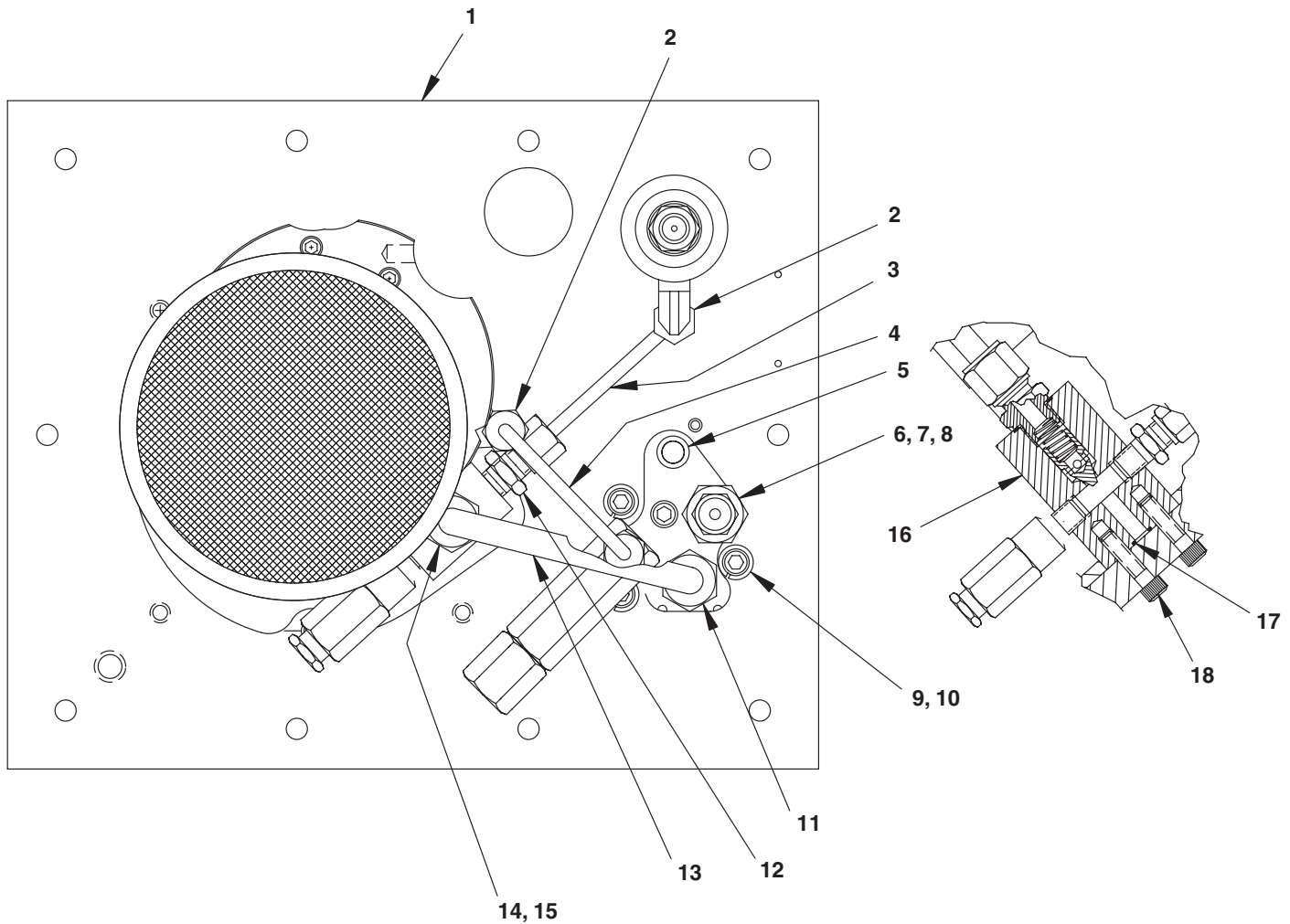

Item No.	Part No.	No. Req'd	Description
1	2000212	1	Plate, Cover
2	16177	2	90° Elbow Fitting
3	2000221	1	Tube, Pressure Regulator
4	253562	1	Tube, Oil Line
5	250630	1	Tube, Drain
6	21278-15	1	Valve, Relief 1500 psi
7	18841	1	Fitting, Straight(1/8 NPTF)
8	15456	1	Fitting, Straight(1/8 NPTF)
9	10008	3	Screw, Socket Hd (1/4-20 x 3/4) (Apply Loctite #243, Torque to 110-120 In. Lbs.)

Item No.	Part No.	No. Req'd	Description
10	10245	3	Washer, Lock (.49 x .26)
11	10661	1	Fitting, Straight(1/4 NPTF)
12	14844	4	Fitting, Straight(1/8 NPTF)
13	351203	1	Tube, Oil Line
14	10430	1	Sleeve, Tube (3/8 Dia.)
15	10431	1	Fitting, Nut Tube 3/8 Tube
16	21277-2	1	Valve, Check and 10,000 psi Relief
17	10266	1	O-Ring (Nitrile .37 x .25)
18	10015	2	Screw, Socket Hd (1/4-28 x 1) (Torque to 130-180 In. Lbs.)

#421429 PRESSURE REGULATOR ASSEMBLY

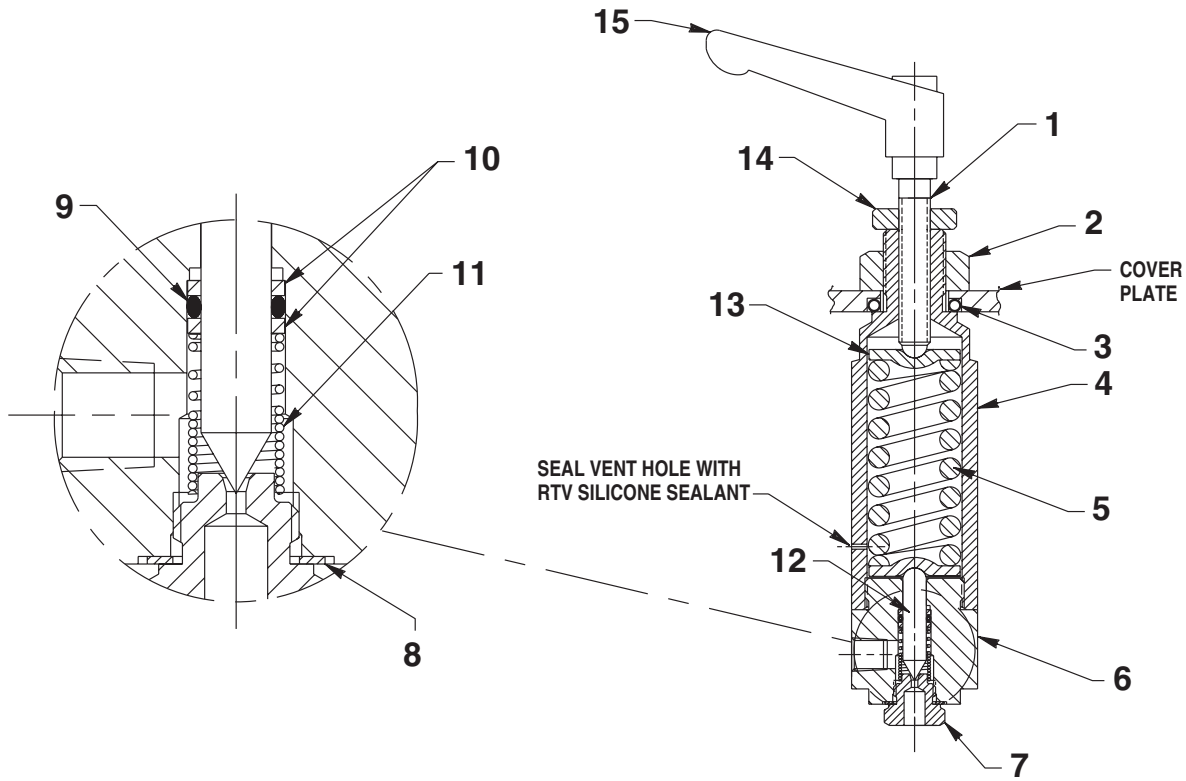

Item No.	Part No.	No. Req'd	Description
1	252427	1	Adjustment Stem (Note: Assemble to handle with Loctite 242 or equiv.)
2	10396	1	Jam Nut (3/4"-16)
3	10527	1	O-ring (Note: Not Included with Assembly)
4	351350	1	Regulator Housing
5	215429	1	Compression Spring (1.100 O.D. X 2-1/2 Lg.)
6	420891	1	Regulator Body
7	351343	1	Seat Fitting (Torque to 440/460 in. lbs.)

Item No.	Part No.	No. Req'd	Description
8	14874	1	Copper Washer (.700 X 1/2 X 1/32)
9	10266	1	O-ring (3/8 X 1/4 X 1/16)
10	215430	2	Backup Washer (.385 x .282 x .050)
11	215431	1	Spring (3/8 O.D. x 21/32 Lg.; Note: Assemble closed coils of spring form towards seat fitting [Item#7])
12	309079	1	Poppet
13	215428	2	Spring Retainer (Grease pocket before assembling [both ends])
14	215683	1	Regulator Locking Nut (3/8-24)
15	252332	1	Adjustable Handle

BASIC PUMP ASSEMBLY

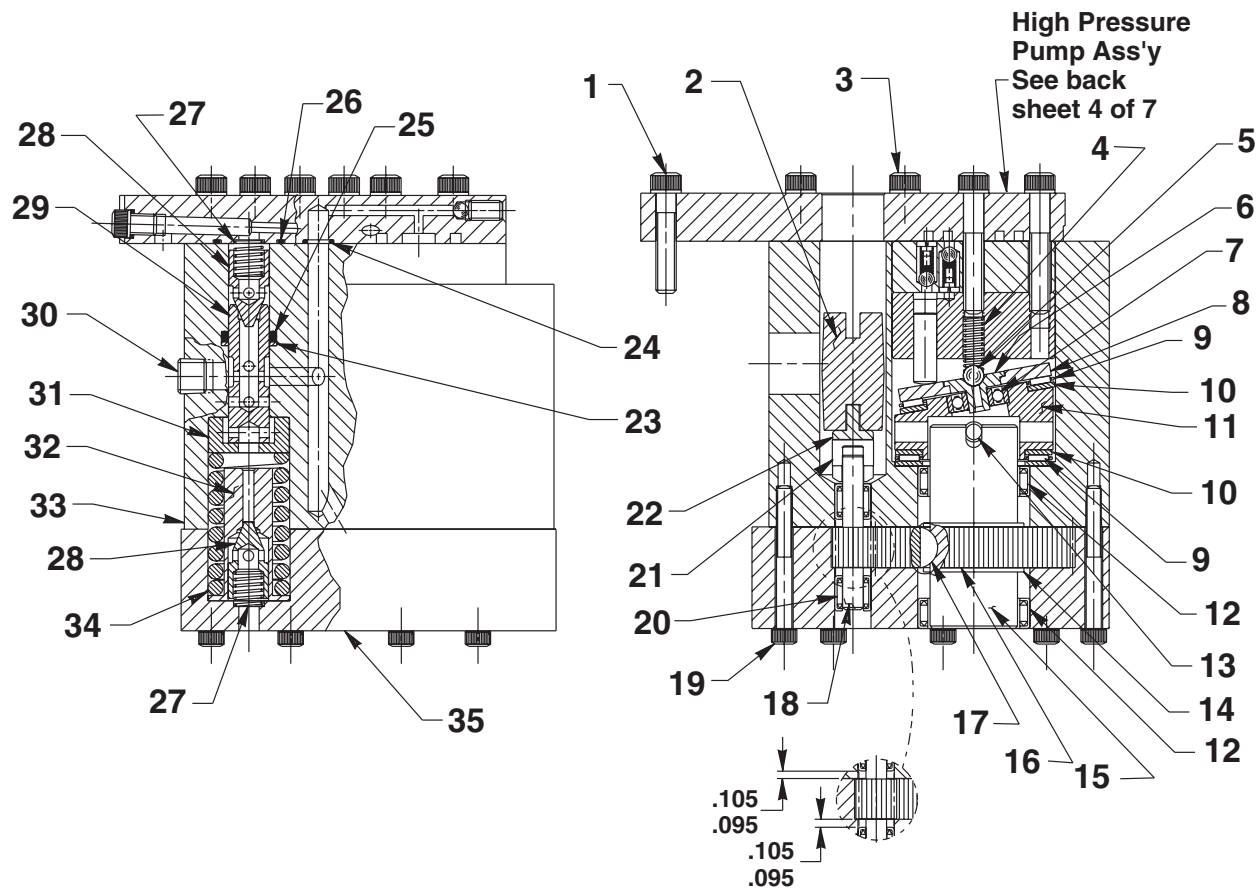

Item No.	Part No.	No. Req'd	Description
1	10016	3	Soc. Hd. Screw (1/4-20 x 1)
2	21091	1	Coupling
3	10020	9	Soc. Hd. Screw (1/4-20 x 1-1/4; Torque to 170/180 in. lbs.)
4	10361	1	Spring (.25 OD x 1" x .03 WS)
5	10375	1	Ball (1/4 dia. steel)
6	23547	1	Bearing Top Plate
7	11814	1	Ball Bearing
8	23548	1	Top Plate
9	11228	2	Needle Bearing
10	11813	3	Bearing Race
11	23549	1	Angle Plate
12	11064	2	Needle Bearing
13	11955	1	Spring Slotted Pin (.25 x 1.75)
14	11261	2	Ext. Retaining Ring (1.05 x .050)
15	23556	1	Shaft
16	23574	1	Drive Gear
17	11821	1	Woodruff Key
18	20774	1	Connector Fitting (9/16 x 5/8)

Item No.	Part No.	No. Req'd	Description
19	10001	13	Soc. Hd. Screw (10-32 x 1-3/4; Torque to 50/60 in. lbs.)
20	11198	2	Needle Bearing
21	21093	1	Key
22	21092	1	Adapter
23	12389	1	Backup Washer (.69 x .50)
24	10266	1	O-ring (.37 x .25 Nitrile)
25	10271	1	O-ring (.68 x .50 Nitrile)
26	10303	1	O-ring (.87 x .75 Nitrile)
27	10425	2	Spring (.37 OD x .75 x .03 WS)
28	20771	2	Poppet
29	0849	1	Spool
30	10427	1	Plug Fitting (1/8 NPTF)
31	23255	1	Spring Guide
32	23256	1	Spring Guide
33	40071	1	Pump Body
34	10426	1	Spring (1" OD x 1.8 x .19 WS)
35	40072	1	End Plate

HIGH PRESSURE PUMP ASSEMBLY

See Diagram
on Reverse
Side for
Important
Ass'y.
Information

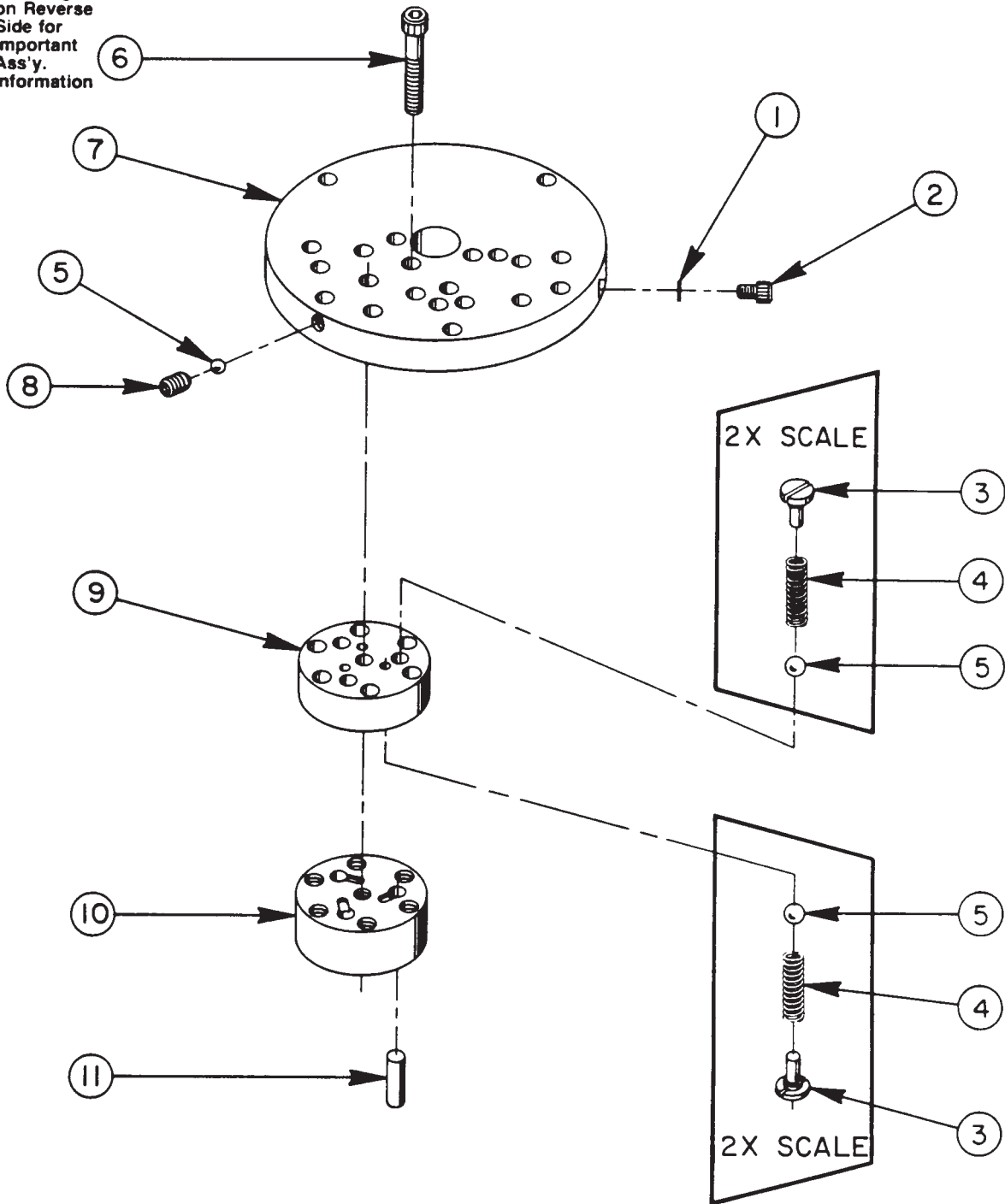

33113 HIGH PRESSURE PUMP ASSEMBLY

3 Pistons --- 9/32 Dia.

Item No.	Part No.	No. Req'd	Description
1	10442	1	Copper Washer
2	10002	1	Soc. Hd. Cap Screw (1/4-20 UNC X 3/8 Lg.; Torque to 140/160 in. lbs.)
3	*24549	6	Valve Guide
4	*10445	6	Compression Spring (5/32 O.D. X 3/4 Lg.)
5	*12223	7	Steel Ball (3/16 dia.)
6	*10023	7	Soc. Hd. Cap Screw (1/4-28 UNF X 1-1/2" Lg.; Torque to 170/180 in. lbs.)
7	*50411	1	Top Plate
8	10519	1	Soc. Set Screw (Torque to 65/70 in. lbs.)
9	*40630	1	Valve Head
10	*41062	1	Pump Barrel
11	*21628	3	Piston

Consult factory when replacing items marked with an asterisk (*).

BOLT TIGHTENING SEQUENCE

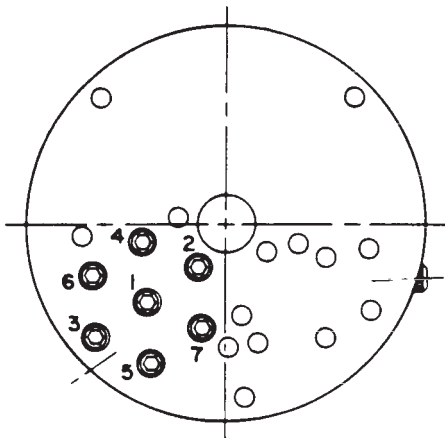

Note: Assemble in sequence shown.
Lubricate under head and on threads.
Torque to 170/180 in. lbs.

MOTOR AND CONTROL ASSEMBLY

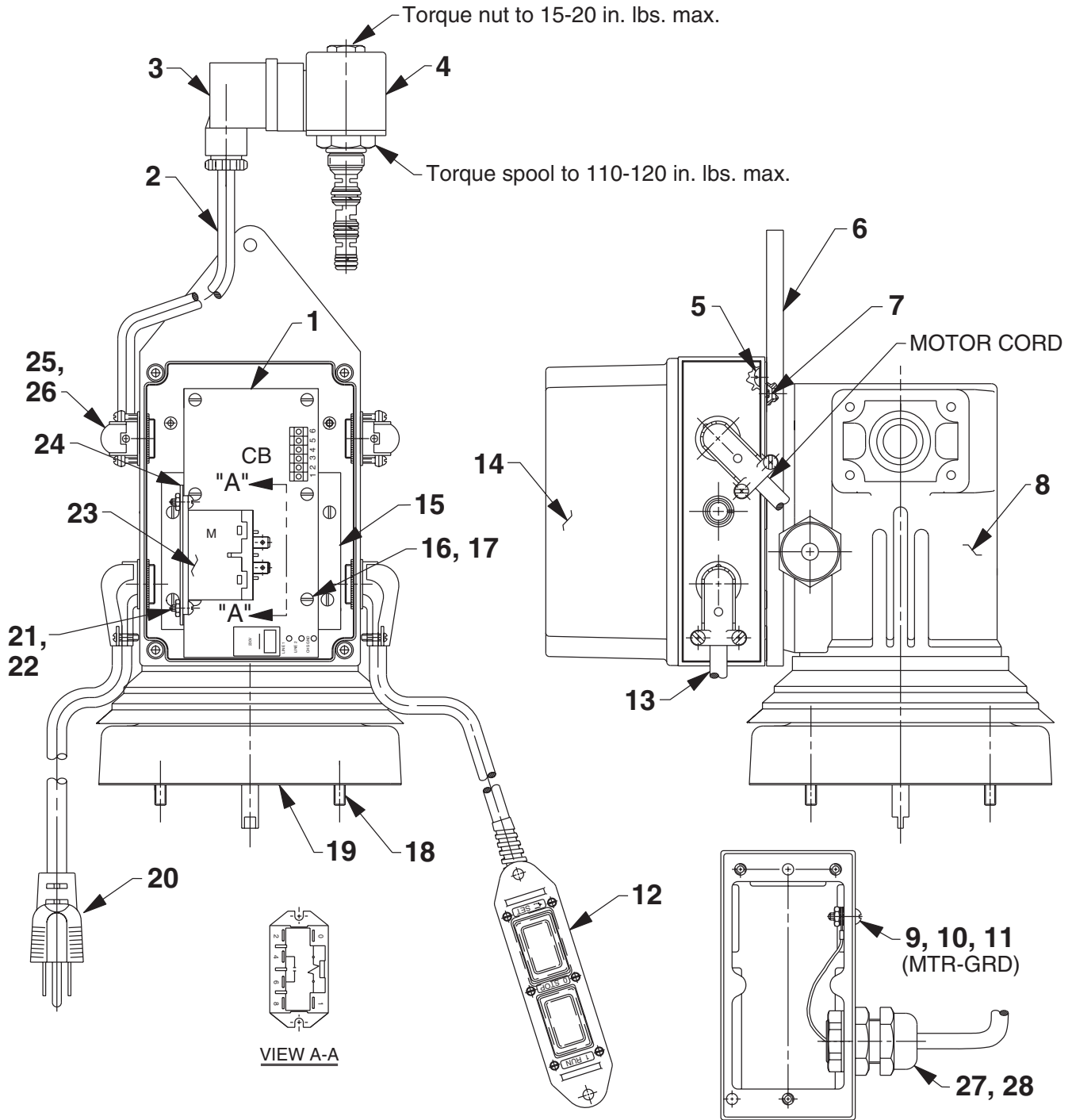

Item No.	Part No.	No. Req'd	Description
1	421477	1	Circuit Board (NOTE: Set input voltage selector switch to 115 v. position.)
2	11423	1.6'	Cable (18/2 SJTO)
3	253405	1	Connector
4	351843	1	Solenoid Valve (4 way 3000 PSI)
5	12409	4	Rnd. Hd. Screw (8-32 x 3/4)
6	2000210WH2	1	Mounting Bracket
7	253140	3	Flat Hd. Screw (10-24 x 5/8)
8	65249	1	Basic Motor (110/115 V. 50/60 Hz.)
9	12354	3	Rnd. Hd. Screw (10-24 x 5/8)
10	11108	3	External Tooth Washer (.40 x .20)
11	10197	3	Hex Nut (10-24)
12	351160	1	Hand Control Assembly (See sheet 6 of 7)
13	308752	1.6'	Cable (14/3 SJTO)
14	59036	1	Control Box

Item No.	Part No.	No. Req'd	Description
15	351588	1	Mounting Plate
16	260071	4	Rnd. Hd. Screw (8-32 x 5/8)
17	11089	2	Flat Washer (.51 x .22)
18	10022	4	Soc. Hd. Screw (1/4-20 x 1-1/2)
19	30650	1	Motor Base Gasket
20	307440	1	Cord (8' lg.; 115 V.; 12/3 SJTO)
21	10447	2	Rnd. Hd. Screw (8-32 x 5/16)
22	10196	2	Hex Nut (8-32)
23	360001	1	Relay (120 volt)
24	351941	1	Mounting Bracket
25	260068	4	Bushing, Strain Relief 90°
26	216680	4	Conduit Locknut
27	216666	1	Conduit Locknut

ELECTRICAL SCHEMATIC

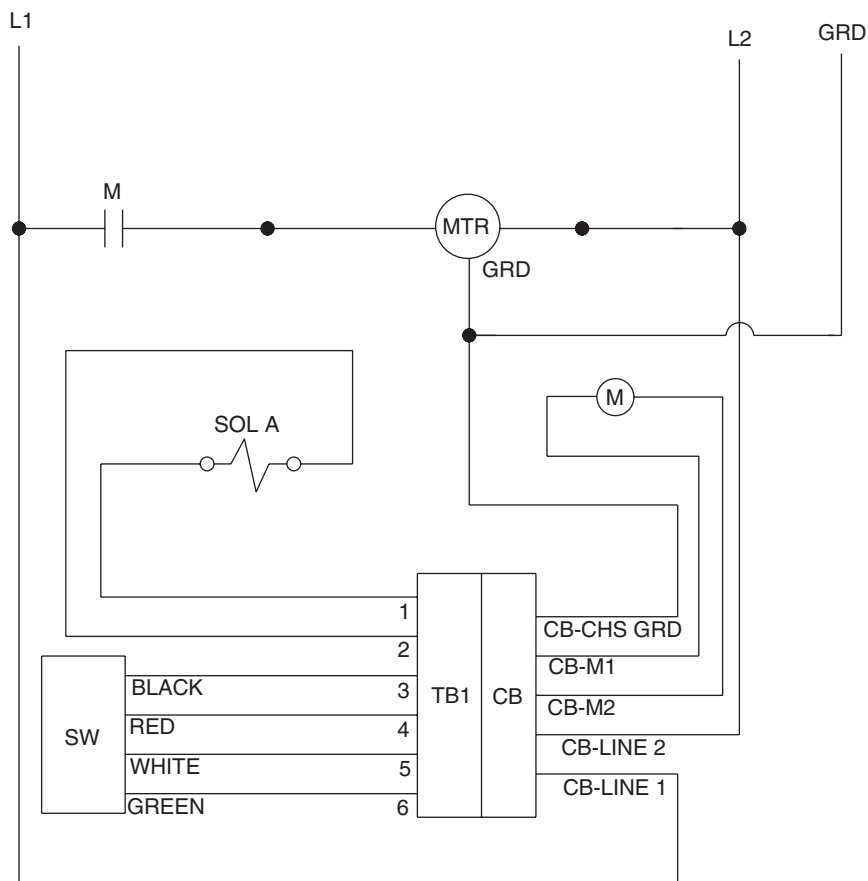

#351160 REMOTE HAND SWITCH ASSEMBLY

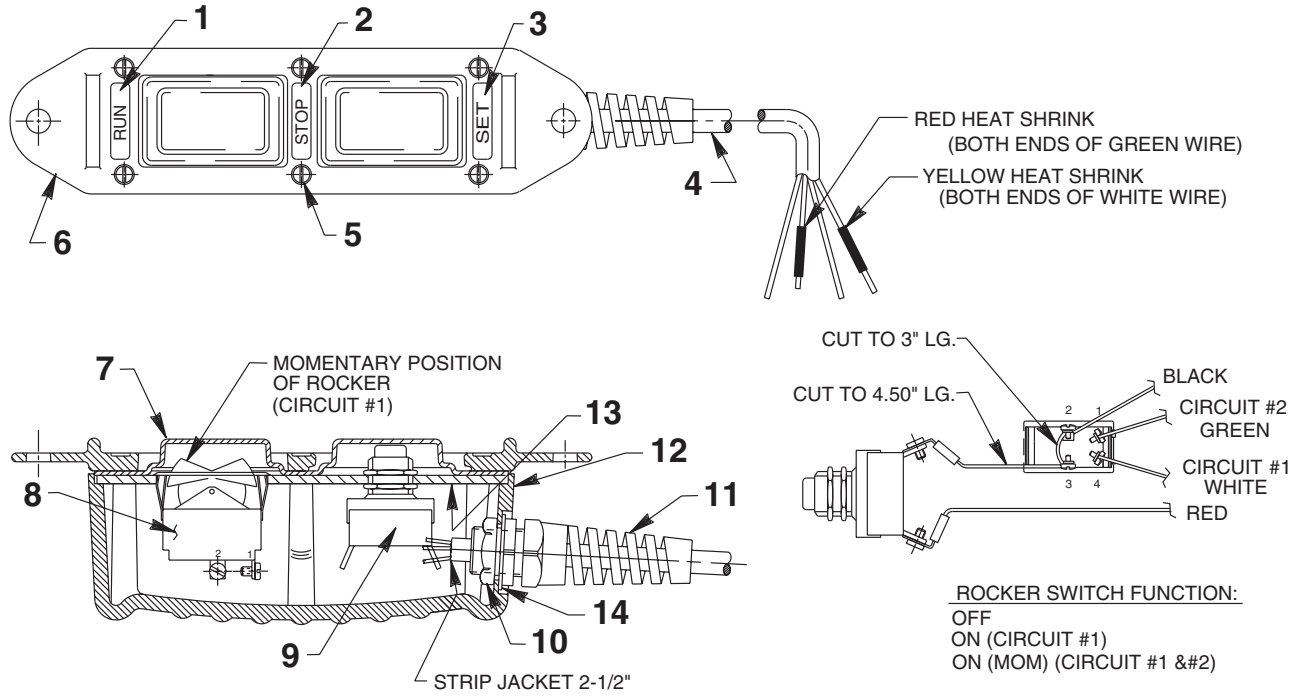

Item No.	Part No.	No. Req'd	Description
1	203770	1	Decal (Run)
2	203769	1	Decal (Stop)
3	252431	1	Decal (Set)
4	11391	21'	Cable (18/4 SJTO)
5	250248	6	Screw (4-24 X 3/4 Lg.)
6	251044	1	Plastic Cover
7	420050-2	1	Gasket

Item No.	Part No.	No. Req'd	Description
8	420017	1	Rocker Switch
9	253197	1	Push Button Switch
10	251802	1	Locknut
11	251818	1	Strain Relief Bushing
12	420050-4	1	Switch Housing
13	420050-5	1	Switch Mounting Plate
14	253607	1	Gasket

ELECTRIC MOTOR ASSEMBLY

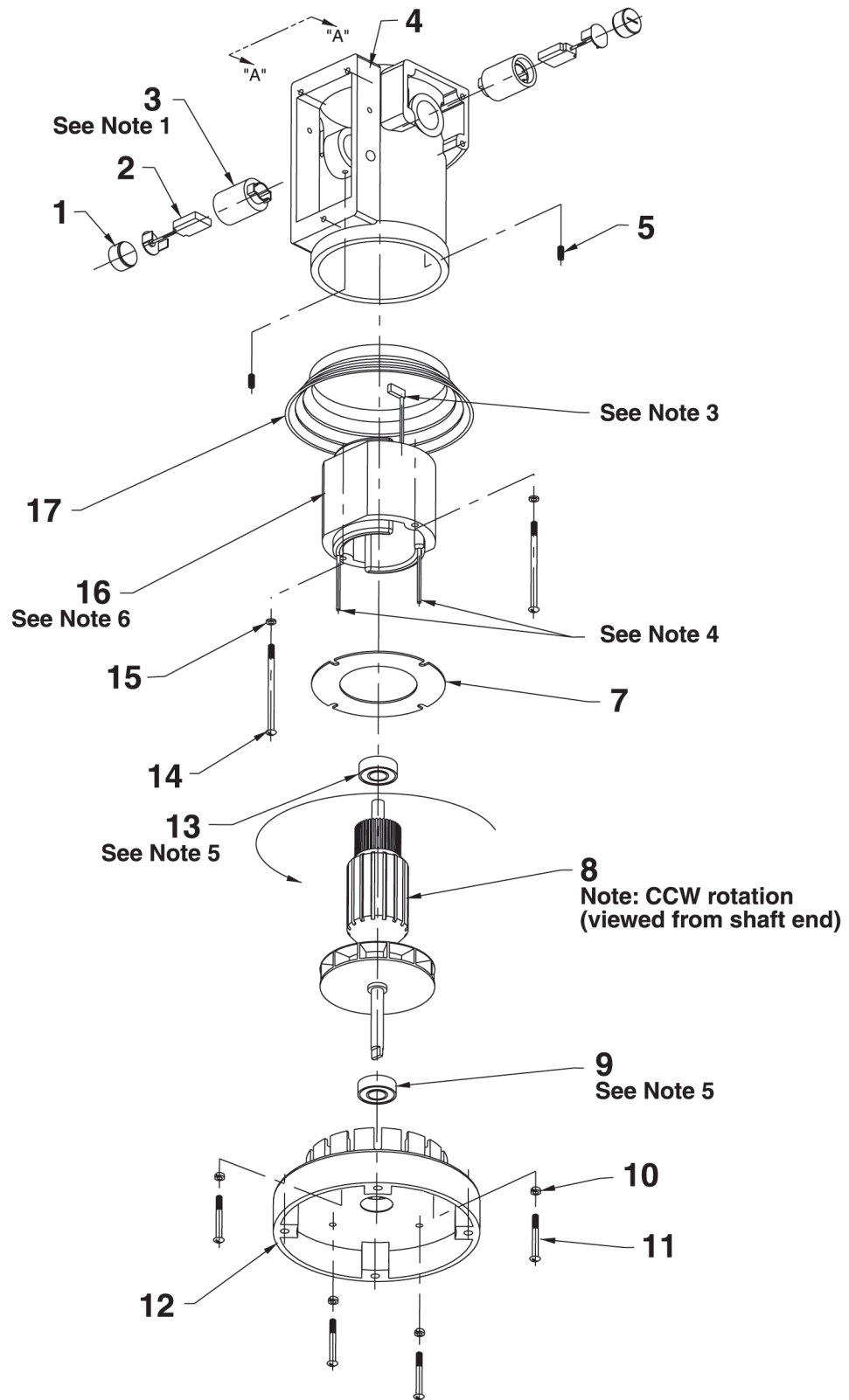

Notes:

1. Brush holders (#10805) must be installed with slot and dimple facing the open end of the motor shell casting.
2. Stator must be installed with part no. and date code up (must be visible thru the rectangular opening in the motor shell casting).
3. Insert flag terminals into adjacent brush holders.
4. Line leads must be routed thru the rectangular opening in the motor shell casting.
5. Press bearings on to armature and install as a unit into the motor shell casting.

Item No.	Part No.	No. Req'd	Description
1	10806	2	Brush Holder Cap
2	10804	2	Brush
3	10805	2	Brush Holder
4	65064	1	Motor Shell
5	10133	2	Set Screw (#10-24 UNC X 1/4 Lg.)
7	20786	1	Baffle Plate
8	10800	1	Armature (115 volt)
9	10438	1	Ball Bearing
10	10241	4	Lockwasher (For #10 bolt)
11	10169	2	Screw (#10-24 UNC X 2" Lg.; Torque to 20/25 in. lbs.)
12	40059WH2	1	Motor Base
13	10439	1	Ball Bearing
14	10170	2	Screw (#10-24 UNC X 3-1/4 Lg.)
15	12356	2	Washer (#10 Internal Tooth)
16	10802	1	Field (115 volt)
17	421204	1	Plastic Cover

BRUSH HOLDER & ARMATURE INSTALLATION SPECIFICATION

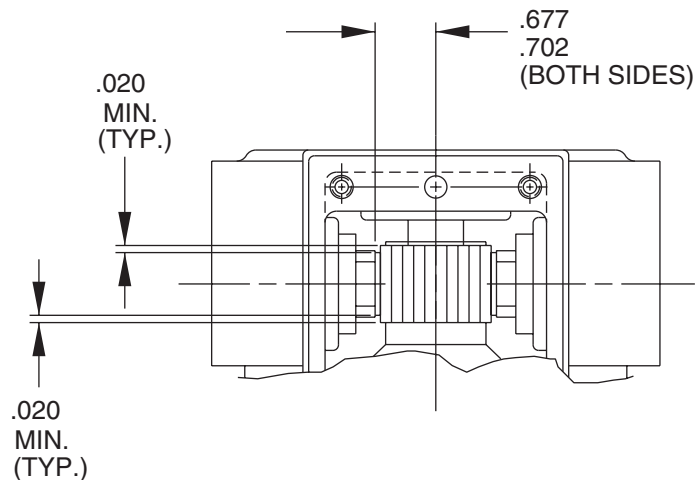

When replacing brushes or the armature, the dimensions shown must be as specified.

**RECOMMENDED MINIMUM WIRE SIZE-AWG (mm²)
OF EXTENSION CORDS FOR
POWER TEAM ELECTRIC PUMPS**

Current At Full Load (Amps)	Cord Size AWG (mm ²) 3.2 Volt Drop			
	Length of Cord			
	0-25 feet (0-8 m)	25-50 feet (8-15 m)	50-100 feet (15-30 m)	100-150 feet (30-45 m)
6	18 (.82)	16 (1.33)	14 (2.09)	12 (3.32)
8	18 (.82)	16 (1.33)	12 (3.32)	10 (5.37)
10	18 (.82)	14 (2.09)	12 (3.32)	10 (5.37)
12	16 (1.33)	14 (2.09)	10 (5.37)	8 (8.37)
14	16 (1.33)	12 (3.32)	10 (5.37)	8 (8.37)
16	16 (1.33)	12 (3.32)	10 (5.37)	8 (8.37)
18	14 (2.09)	12 (3.32)	8 (8.37)	8 (8.37)
20	14 (2.09)	12 (3.32)	8 (8.37)	6 (13.30)
22	14 (2.09)	10 (5.37)	8 (8.37)	6 (13.30)
24	14 (2.09)	10 (5.37)	8 (8.37)	6 (13.30)
26	12 (3.32)	10 (5.37)	8 (8.37)	6 (13.30)
28	12 (3.32)	10 (5.37)	6 (13.30)	4 (21.29)
30	12 (3.32)	10 (5.37)	6 (13.30)	4 (21.29)