

SPX Hydraulic Technologies
5885 11th Street
Rockford, IL 61109-3699 USA
powerteam.com

Tech. Services: (800) 477-8326
Fax: (800) 765-8326
Order Entry: (800) 541-1418
Fax: (800) 288-7031

Electric-Powered
**18 Series
Hydraulic Pump**



Table of Contents

Description	2
PE18-Series Electric / Hydraulic Pumps	2
Control Valves	3
Safety Symbols and Definitions	5
Safety Precautions	5
Initial Setup	9
Operating Instructions	12
Performance Specifications	15
General Maintenance	16
Troubleshooting Guide	19
Power Team Facilities	22

Description

The 18 series hydraulic pumps are designed to have a maximum of 690 bar (10,000 psi) at a flow rate of 295 cc/min (18 cu. in/min). A pump can be valved for use with either single- or double-acting cylinders. All pumps come fully assembled, less fluid, and ready for work.

PE18-Series Electric / Hydraulic Pumps

Electric Motor

The electric motor is available in a 0.4 kW (1/2 HP).
The motor is in single-phase configuration.

The electric motor offers a low noise level due to moderate speed. This motor is ideal for long service, fixed applications.

The 1/2 hp, 110/115 or 220/230 VAC, 60/50 Hz single phase motor starts under load, even at reduced voltage.

The weight can be up to 29 kg (63 lbs).



Figure 1. Electric Motor

Control Valves

Max. Capacity: 690 bar (10,000 psi)

PE182	Valve Function	Use with Cylinder Type	Valve No.
	<div style="display: flex; justify-content: space-around;"> <div style="text-align: center;"> <p>Position "A"</p> <p>From Pump To Tank</p> </div> <div style="text-align: center;"> <p>Position "B"</p> <p>From Pump To Tank</p> </div> </div>	Single-acting	2-way advance return
Diagrams			
NOTE: All ports OPEN to tank during transition between valve positions.			

PE183 PE183-2	Valve Function	Use with Cylinder Type	Valve No.
	<div style="display: flex; justify-content: space-around;"> <div style="text-align: center;"> <p>Position "A"</p> <p>From Pump To Tank</p> </div> <div style="text-align: center;"> <p>Center Position</p> <p>From Pump To Tank</p> </div> <div style="text-align: center;"> <p>Release Position</p> <p>From Pump To Tank</p> </div> </div>	Single-acting	3-way advance hold return
Diagrams			
NOTE: All ports OPEN to tank during transition between valve positions.			

PE183A	Valve Function	Use with Cylinder Type	Valve No.
	<div style="display: flex; justify-content: space-around;"> <div style="text-align: center;"> <p>Advance Pump "ON"</p> <p>To Tank From Pump</p> </div> <div style="text-align: center;"> <p>Retract Pump "OFF"</p> <p>To Tank From Pump</p> </div> </div>	Single-acting	Auto/dump pump, advance return
Diagrams			
NOTE: All ports OPEN to tank during transition between valve positions.			

Table 1. Pump Configurations

Control Valves continued

PE183C	Valve Function	Use with Cylinder Type	Valve No.
	<div style="display: flex; justify-content: space-around;"> <div style="text-align: center;"> <p>Advance Pump "ON" Solenoid "ON"</p> <p>To Tank From Pump</p> </div> <div style="text-align: center;"> <p>Hold Pump "OFF" Solenoid "ON"</p> <p>To Tank From Pump</p> </div> <div style="text-align: center;"> <p>Retract Pump "OFF" Solenoid "OFF"</p> <p>To Tank From Pump</p> </div> </div>	Single-acting	Special, for crimping only, advance hold return
Diagrams			

NOTE: All ports OPEN to tank during transition between valve positions.

PE184 PE184-2	Valve Function	Use with Cylinder Type	Valve No.
	<div style="display: flex; justify-content: space-around;"> <div style="text-align: center;"> <p>Position "A"</p> <p>From To</p> </div> <div style="text-align: center;"> <p>Center Position</p> <p>From To</p> </div> <div style="text-align: center;"> <p>Position "B"</p> <p>From To</p> </div> </div>	Single and double-acting	4-way advance hold return
Diagrams			

NOTE: All ports OPEN to tank during transition between valve positions.

PE184C	Valve Function	Use with Cylinder Type	Valve No.
	<div style="display: flex; justify-content: space-around;"> <div style="text-align: center;"> <p>Position "A"</p> <p>From Valve Port To Tank</p> </div> <div style="text-align: center;"> <p>Position "B"</p> <p>From Valve Port To Tank</p> </div> </div> <div style="display: flex; justify-content: space-around; margin-top: 20px;"> <div style="text-align: center;"> <p>Advance Pump "ON" Solenoid "ON"</p> <p>To Tank From Pump</p> </div> <div style="text-align: center;"> <p>Hold Pump "OFF" Solenoid "ON"</p> <p>To Tank From Pump</p> </div> <div style="text-align: center;"> <p>Retract Pump "OFF" Solenoid "OFF"</p> <p>To Tank From Pump</p> </div> </div>	Single and double-acting	4-way advance return
Diagrams			

NOTE: All ports OPEN to tank during transition between valve positions.

Table 1. Pump Configurations (continued)

Safety Symbols and Definitions

The safety signal word designates the degree or level of hazard seriousness.



DANGER: Indicates an imminently hazardous situation which, if not avoided, will result in death or serious injury.



WARNING: Indicates a potentially hazardous situation which, if not avoided, could result in death or serious injury.



CAUTION: Indicates a potentially hazardous situation which, if not avoided, may result in minor or moderate injury.

CAUTION: Used without the safety alert symbol indicates a potentially hazardous situation which, if not avoided, may result in property damage.

IMPORTANT: Important is used when action or lack of action can cause equipment failure, either immediate or over a long period of time.

Safety Precautions



WARNING:



- The following procedures must be performed by qualified, trained personnel who are familiar with this equipment. Operators must read and understand all safety precautions and operating instructions included with the pump. If the operator cannot read these instructions, operating instructions and safety precautions must be read and discussed in the operator's native language.

- These products are designed for general use in normal environments. These products are not designed for lifting and moving people, agri-food machinery, certain types of mobile machinery, or in special work environments such as: explosive, flammable, or corrosive. Only the user can decide the suitability of this product in these conditions or extreme environments. Power Team will supply information necessary to help make these decisions. Consult your nearest Power Team facility.



- Safety glasses must be worn at all time by the operator and anyone within sight of the unit. Additional personal protection equipment may include: face shield, goggles, gloves, apron, hard hat, safety shoes, and hearing protection.



- The owner of this tool must ensure that safety-related decals are installed, maintained, and replaced if they become hard to read.



- Shut OFF the motor before opening any connections in the system.
- The guide cannot cover every hazard or situation so always do the job with SAFETY FIRST.

Pump



WARNING:

- Do not exceed the hydraulic pressure rating noted on the pump nameplate or tamper with the internal high pressure relief valve. Creating pressure beyond rated capacities can result in personal injury.
- Retract the system before adding fluid to prevent overflowing the pump reservoir. An overflow can cause personal injury due to excess reservoir pressure created when cylinders are retracted.
- The load must be under operator control at all times.

Safety Precautions continued

- Do not connect pump to hydraulic system powered by another pump.

Electric Motor



WARNING:

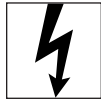

- Electrical work must be performed and tested by a qualified electrician per local directives and standards.
- Disconnect the pump from the power supply and relieve pressure before removing the motor case cover or performing maintenance or repair.
- Check the total amperage draw for the electrical circuit you will be using. *For example: Do not connect a pump that may draw 25 amps to a 20 amp fused electrical circuit.*
- Never use an ungrounded power supply with this unit.
- Changing the voltage is an involved and, if incorrectly performed, hazardous procedure. Consult the manufacturer for specific information before attempting rewiring.
- Wire pump motors for counterclockwise rotation when viewed from the shaft end of the motor.



- Do not attempt to increase the power line capacity by replacing a fuse with another fuse of higher value. Overheating the power line may result in fire.
- Exposing electric pumps to rain or water could result in an electrical hazard.
- Avoid conditions that can cause damage to the power cord, such as abrasion, crushing, sharp cutting edges, or corrosive environment. Damage to the power cord can cause an electrical hazard.

Hoses



WARNING:



- Before operating the pump, tighten all hose connections using the correct tools. Do not overtighten. Connections should be only secure and leak-free. Overtightening can cause premature thread failure or high pressure fittings to split at pressures lower than their rated capacities.
- Should a hydraulic hose rupture, burst, or need to be disconnected, immediately shut off the pump and shift the control valve twice to release pressure. Never attempt to grasp a leaking hose under pressure with your hands. The force of escaping hydraulic fluid could cause serious injury.



- Do not subject the hose to potential hazard, such as fire, sharp surfaces, heavy impact, or extreme heat or cold. Do not allow the hose to kink, twist, curl, or bend so tightly that the fluid flow within the hose is blocked or reduced. Periodically inspect the hose for wear, because any of these conditions can damage the hose and possibly result in personal injury.
- Do not use the hose to move attached equipment. Stress can damage the hose and possibly cause personal injury.
- Hose material and coupler seals must be compatible with the hydraulic fluid used. Hoses also must not come in contact with corrosive material such as creosote-impregnated objects and some paints. Consult the manufacturer before painting a hose. Never paint the couplers. Hose deterioration due to corrosive materials may result in personal injury.

Safety Precautions continued

- Avoid straight line tubing connections in short runs. Straight line runs do not provide for expansion and contraction due to pressure and/or temperature changes.
- Eliminate stress in the tube lines. Long tubing runs should be supported by brackets or clips. Tubes through bulkheads must have bulkhead fittings. This makes easy removal possible and helps support the tubing.
- Carefully inspect all hoses and fittings prior to use. Before each use, check entire hose for cuts, leaks, abrasion or bulging of cover, or damage or movement of couplings. If any of these conditions exist, replace the hose immediately. NEVER attempt to repair the hose.

Cylinder



DANGER:

- Do not exceed rated capacities of the cylinders. Excess pressure may result in personal injury.
- Avoid off-center loads that could damage the cylinder and/or cause loss of the load.
- Read and understand all safety and warning decals and instructions for devices attached.
- Inspect each cylinder and coupler before each shift or usage to prevent unsafe conditions from developing.
- Do not use cylinders if they are damaged, altered or in poor condition.
- Do not use cylinders with bent or damaged couplers or damaged port threads.
- Under certain conditions, the use of an extension with a hydraulic cylinder may not be advisable and could present a dangerous condition.
- Avoid pinch points or crush points that can be created by the load or parts of the cylinder.
- To help prevent material fatigue if the cylinder is to be used in a continuous application, the load should not exceed 85% of the rated capacity or stroke.
- Cylinder must be on a stable base which is able to support the load while pushing or lifting.
- To help prevent personal injury, use shims, friction material or constraints to prevent slippage of the base or load.
- Do not set poorly-balanced or off-center loads on a cylinder.
- The load can tip or the cylinder can “kick out” and cause personal injury.
- Do not use the locking collar on a threaded piston as a stop. The threads may shear resulting in loss of the load.
- If this component is used to lift or lower loads, be certain that the load is under operator control at all times and that others are clear of the load.
- Do not drop the load.
- As the load is lifted, use blocking and cribbing to guard against a falling load.
- To help prevent personal injury, do not allow personnel to go under or work on a load before it is properly cribbed or blocked. All personnel must be clear of the load before lowering.
- Never use extreme heat to disassemble a hydraulic cylinder or ram. Metal fatigue and/



Safety Precautions continued

or seal damage will result and can lead to unsafe operating conditions.

IMPORTANT

- **Keep the cylinder clean at all times.**
- **While at a job site, when the cylinder is not in use, keep the piston rod fully retracted and upside down.**
- **Always use protective covers on disconnected quick couplers.**
- **When mounting cylinders or rams using the internal piston rod threads, collar threads, threaded tie rods or base mounting holes, the threads must be fully engaged. Always use SAE grade 8 or better fasteners when attaching components to cylinders or rams and tighten securely.**
- **Limiting the stroke and pressure on all cylinders will prolong their life.**

Initial Setup

1. Remove all packing materials from the assembled unit.
2. Inspect the unit upon arrival. The carrier, not the manufacturer, is responsible for any damage resulting from shipment.

Filling the Pump Reservoir

Most pumps are shipped without hydraulic fluid in the reservoir. Hydraulic fluid may have been shipped in a separate container, but if hydraulic fluid is needed, use only approved Power Team hydraulic fluid rated at AW 46 47 cSt @ 38°C (237 SUS @ 100°F). If low temperature requirements are needed, use hydraulic fluid 5.1 cSt @ 100°C (451 cSt @ -40°C).

1. Clean the area around the filler cap to remove debris. Debris in the hydraulic fluid can damage the polished surfaces and precision-fit components of this pump.
2. Remove the filler cap and insert a clean funnel with a filter.
3. Fill the reservoir with hydraulic fluid to 1.3 cm (0.5 in.) from the cover plate.
4. Replace the filler cap. Verify the breather-hole is open, if applicable.

Hydraulic Connections

1. Clean the areas around the fluid ports of the pump and cylinders.
2. Inspect all threads and fittings for signs of wear or damage, replace as needed.
3. Clean all hose ends, couplers or union ends.
4. Remove the thread protectors from the hydraulic fluid outlets.
5. Connect the hose assembly to the hydraulic fluid outlet, and couple the hose to the cylinder.



CAUTION: To prevent personal injury from leaking hydraulic fluid, seal all hydraulic connections with a high-quality, non-hardening, pipe thread sealant.



IMPORTANT: Sealant tape or non hardening sealer tape can be used to seal hydraulic connections if only one layer of tape is used. Apply tape carefully, two threads back, to prevent it from being pinched by the coupler and broken off inside the system. Loose pieces of sealant could travel through the system and obstruct the flow of fluid or cause jamming of precision-fit parts.

Electric Motor Operation

The electric motor is wired for nominal 115 or nominal 230 volts, 50/60 Hz. Some motors can be rewired. Consult Power Team technical support.

1. Verify the hydraulic valve is in the neutral or hold position.
2. Connect the motor to a power supply.

Caution:

- **The correct voltage is required for the pump to operate. Verify the voltage rating on the pump motor name plate matches the outlet or power source you are using. Low voltage may cause: an overheated motor; a motor that fails to start under load; motor surging when trying to start; or a stalled motor before maximum pressure is reached.**
- **Check the voltage at the motor with the pump running at full pressure.**
- **Never run the motor on long, light gauge extension cords. Refer to Table 2. Minimum Recommended Gauge Table.**

Initial Setup continued

3. Start the pump and shift as required.
4. Turn off the pump when not in use.

AMPS at Maximum Hyd. Pressure	Electrical Cord Size AWG (mm ²) 3.2 Volt Drop Length of Electrical Cord							
	mm ²				AWG			
	0-8 m	8-15 m	15-30 m	30-46 m	0-25 ft	25-50 ft	50-100 ft	100-150 ft
6	0.75	1	1.5	2.5	18	16	14	12
10	0.75	1.5	2.5	4	18	14	12	10
14	1	2.5	4	6	16	12	10	8
18	1.5	2.5	6	6	14	12	8	8
22	1.5	4	6	10	14	10	8	6
26	2.5	4	6	10	12	10	8	6
30	2.5	4	10	16	12	10	6	4

Table 2. Minimum Recommended Gauge Table

Bleeding Air from the System

Air can accumulate in the hydraulic system during the initial set-up or after prolonged use causing the cylinder to respond slowly or in an unstable manner. To remove the air:

1. Open the filler plug two full turns.
2. See Figure 2. Place the cylinder at a lower level than the pump.
3. Extend and retract the cylinder several times without putting a load on the system. Air will be released through the pump reservoir.
4. Cycle the hydraulic system until operation is smooth and consistent.
5. Check the pump reservoir level. Add Power Team hydraulic fluid as needed.

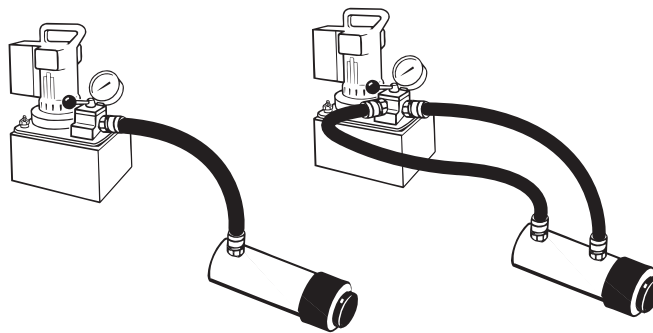

Figure 2. System Bleeding

IMPORTANT: Some spring return cylinders or rams have a cavity in the rod which forms an air pocket. This type of cylinder or ram should be bled when positioned upside down or lying on its side with the port facing upward.

Hydraulic Pressure Gauge (optional)

Note: Hose can thread directly into pump body.

To install a hydraulic pressure gauge:

1. See Figure 3. For 18-series pumps not equipped with a gauge port a T-adaptor (PN 9760) is necessary. Install Tee fitting.
2. Install sealant tape or non-hardening sealer to a T-adaptor. Install the T-adaptor as shown.
3. Install sealant tape or non hardening sealer to the gauge.
4. Install the pressure gauge.

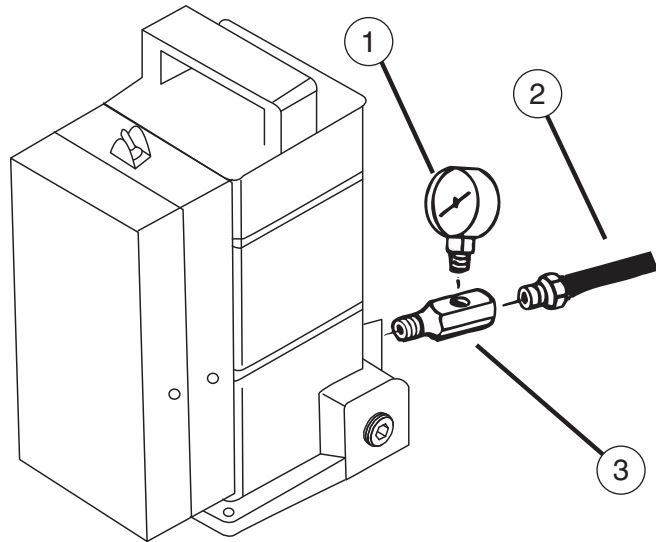

Item	Description
1	Gauge
2	Hose
3	T-adaptor

Figure 3. 18-Series Gauge

Operating Instructions

1. Open the filler plug two full turns to vent the reservoir.
2. Place the control valve in the neutral position.
3. Insert the power cord into an outlet.

⚠ WARNING: To help prevent personal injury, check the voltage rating on the motor nameplate to be sure the outlet has the right voltage.

Priming the Pump (if equipped)

1. Back the priming screw out two complete turns.
2. Cycle the pump three times.
3. Tighten the priming screw to 2–3 Nm (15–25 in. lbs.)

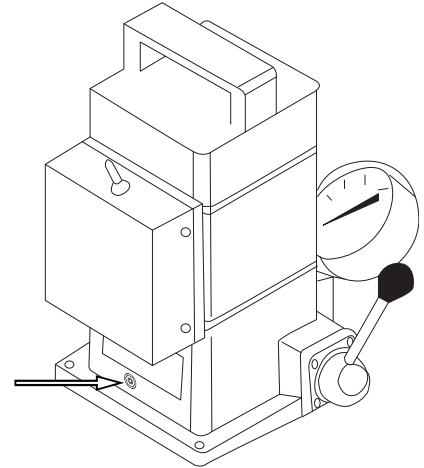

Figure 4. PE18 Priming Screw

Electric Motor Control Operation

1. Connect the power cord to an appropriate power source.
2. See Figure 5. Place the motor control switch in the ON position or the REMOTE position, if applicable.

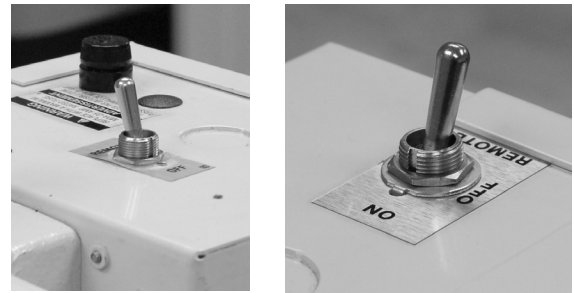

Figure 5. Motor Control Switches

3. Depending on system requirements:

See Figure 6. This remote will start and run the pump motor as long as the switch is pressed. The switch will automatically return to OFF position when switch is released and pump motor will turn off.



Figure 6. Momentary ON-OFF Push Button Remote Motor Control

See Figure 7. This remote will start and run the pump motor to advance or retract the cylinder when released it allows the pressure to be held.

1. Press the rocker switch toward the Advance side of the switch and hold to extend the cylinder.
2. Press the rocker switch toward the Retract side of the switch and hold to retract the cylinder.
3. Release the rocker switch and the pump will stop but the system will hold. Generally used on 4-Way-2-Position valves.



Figure 7. Advance-Hold-Retract Remote

Adjusting The Pressure Regulating Valve (if equipped). All others are factory preset.

Note: For easy adjustment of the pressure regulating valve, always adjust the pressure by increasing to the desired pressure setting.

1. Loosen the locknut on the pressure regulating valve.
2. Use a screwdriver to back out the adjusting screw a few turns in a counterclockwise direction. This decreases the setting to a lower-than-desired pressure.
3. The pump must be completely connected. Set the motor control toggle switch on RUN, and push the START switch.
4. With the screwdriver, slowly turn the adjusting screw in a clockwise direction. This gradually increases the pressure setting. When the desired pressure is reached, lock the adjusting screw in position by tightening the locknut.

Notes:

- *The pressure range is from 69-690 bar (1,000-10,000 psi), depending on the pump model.*
- *The pressure switch must be set at a higher pressure than working range to prevent shut down during adjustment. It is also possible to bypass the pressure switch contacts by holding the start switch or remote control switch so the motor runs continuously.*

Operating Instructions continued

Adjusting The Pressure Switch (for Electric Units)

Generally, the pressure switch should be used with the pressure regulating valve and used in a hydraulic circuit where system pressure must be “held”. It automatically (electrically) turns off the pump motor when the predetermined system pressure is reached. It either attaches directly to the control valve manifold or can be mounted “in-line” to read system pressure. It has a 1/4" NPTF male thread, and a 1/4" NPTF fitting for gauge mounting, if required, and is adjustable from 69 to 690 bar (1,000 to 10,000 psi). This can also be used to actuate other electrical devices in the system and is wired “normally open” and held closed by spring pressure.

1. Loosen the locknut on the pressure switch, and turn the adjusting screw in a clockwise direction. This increases the pressure setting to a higher than desired pressure.
2. Adjust the pressure regulating valve to the desired pressure setting by using the procedure previously outlined.
3. With the pump running and bypassing fluid at the desired pressure, slowly turn the pressure switch adjusting screw in a counterclockwise direction, decreasing the pressure switch setting until the pump motor shuts off.
4. Lock the adjusting screw in position by tightening the locknut.
5. Release pressure. Run the pump to check the pressure setting and cut-out of the motor. It may be necessary to make a second adjustment.

Note: When the pressure switch setting is reached, the motor shuts off. However, the “coast” of the motor continues to deliver fluid for a brief period. The pressure regulating valve bypasses this surplus fluid, preventing it from going into the system. As a result, the pressure differential can be held to approximately 20 bar (300 psi).

Performance Specifications

The information in the following charts can be used as a basis to determine if the system is performing as expected during operation.

Pump	RPM	Amp Draw at 690 bar (10,000 psi) (115V)	Amp Draw at 690 bar (10,000 psi) (230V)	dB A at Idle and 690 bar (10,000 psi)	Air Supply Req'd bar (psi)
PE18	12,000	10.2	N/A	85/90	N/A

Table 3. Drive Unit Requirements

Pump	Max. Pressure Output bar (psi)	Fluid Delivery* (cu. in./min. @)					
		0 bar (0 psi)	7 bar (100 psi)	50 bar (700 psi)	70 bar (1,000 psi)	345 bar (5,000 psi)	690 bar (10,000 psi)
PE18	690 bar (10,000 psi)	230	190	-	-	25	18

* Typical delivery. Actual flow varies with field conditions.

Table 4. Fluid Pressure Chart

General Maintenance



WARNING:



- **Disconnect the unit from the power supply before performing maintenance or repair procedures.**
- **Repairs and maintenance are to be performed in a dust-free area by a qualified technician.**

System Evaluation

The components of your hydraulic system — cylinders, pumps, hoses, and couplings — all must be:

- Rated for the same maximum operating pressure.
- Correctly connected.
- Compatible with the hydraulic fluid used.

A system that does not meet these requirements can fail, possibly resulting in serious injury. If you are in doubt about the components of your hydraulic system, contact Power Team Technical Support.

Inspection

Keep a dated and signed inspection record of the equipment. Before each use, the operator or other designated personnel should visually inspect for the following conditions:

- Cracked or damaged cylinder.
- Excessive wear, bending, damage, or insufficient thread engagement.
- Leaking hydraulic fluid.
- Scored or damaged piston rod.
- Incorrectly functioning or damaged heads and caps.
- Loose bolts or cap screws.
- Damaged or incorrectly assembled accessory equipment.
- Modified, welded, or altered equipment.
- Bent or damaged couplers or port threads.

Periodic cleaning



WARNING: Contamination of the hydraulic fluid could cause the valve to malfunction. Loss of the load or personal injury could result.

Establish a routine to keep the hydraulic system as free from debris as possible.

- Seal unused couplers with dust covers.
- Keep hose connections free of debris. Equipment attached to a cylinder must be kept clean.
- Keep the breather-hole in the filler cap clean and unobstructed.
- Use only Power Team hydraulic fluid. Replace hydraulic fluid as recommended, or sooner if the fluid becomes contaminated. Never exceed 300 hours of use between fluid changes.

Hydraulic Fluid Level

1. Check the fluid level in the reservoir after each 10 hours of use. The fluid level should be 1.3 cm (0.5 in.) from the top of the fill hole when all cylinders are retracted.
2. Drain, flush, and refill the reservoir with an approved Power Team hydraulic fluid after every 300 hours of use. The frequency of fluid changes depends upon general working conditions, severity of use, the overall cleanliness and care given to the pump. Fluid should be changed more frequently

when the system is not operated regularly indoors.

Draining And Flushing The Reservoir

1. Clean the pump exterior before the pump interior is removed from the reservoir.
2. Remove the screws fastening the motor and pump assembly to the reservoir. If equipped with a 2-gallon reservoir the screws need to be discarded.
3. Remove the motor assembly and place aside.

Caution: Do not damage the pump filter or pressure regulating valves when lifting the pump and motor off the reservoir.

4. Clean the inside of the reservoir, and fill with Power Team hydraulic fluid. Rinse the filter clean.
5. Place the pump and motor assembly back onto the reservoir, and secure with two machine screws assembled on opposite corners of the housing.
6. Place the hydraulic flow control valve in the neutral position. If the pump is equipped with a valve that has only an advance or retract position.
7. Run the pump for several minutes.
8. Disconnect the motor and pump assembly, and drain and clean the inside of the reservoir.
9. Fill the reservoir with Power Team hydraulic fluid.
10. For pumps with 2-gallon reservoir, use new screws: Place the pump and motor assembly (with new gasket) on the reservoir, and install the new screws. Tighten screws securely and evenly.
For pumps with small reservoirs: Place the pump and motor assembly with clean gasket on the reservoir, and install the screws. Tighten screws securely and evenly.

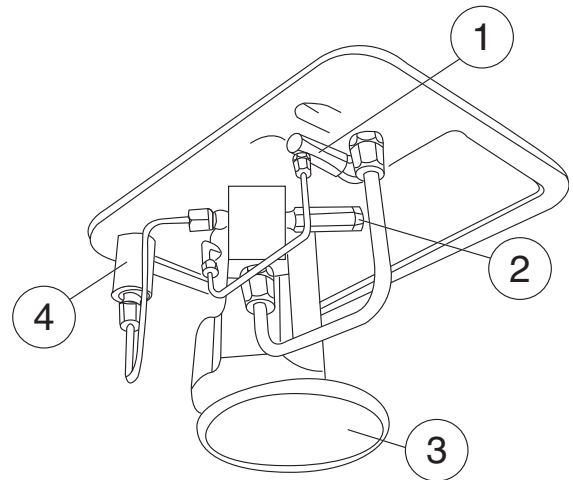

Item	Description
1	Accumulator (Not used on all models)
2	High Pressure Relief Valve
3	Filter
4	Pressure Regulating Valve

Figure 8. Pump Assembly

Adding Hydraulic Fluid To The Reservoir

1. Retract the cylinder(s) devices.
2. Disconnect the power supply.
3. Clean the entire area around the filler plug.
4. Remove the filler plug, and install a clean funnel with a filter.
5. Use only Power Team hydraulic fluid AW 46 47 cSt @ 38°C (247 SUS @ 100°F). If low temperature requirements are needed, use hydraulic fluid 5.1 cSt @ 100°C (451 cSt @ -40°C).

General Maintenance continued

Sound Reduction - Electrically Powered Motor

The electrically powered hydraulic pump operates in the 85-90 dB A range. If further sound reduction is desired, any of the following options will help reduce the sound level.

1. Install a pressure switch to automatically shut off the motor when maximum pressure is reached (holding cycle).
2. Install casters (7.5L (2 Gallon) reservoir only).
3. Contact Power Team Hydraulic Technology technical support for products more suitable to your application.

Hose Connections



CAUTION: Contamination of the hydraulic fluid could cause the valve to malfunction. Loss of the load or personal injury could result.



IMPORTANT: Sealant tape or non-hardening sealer tape can be used to seal hydraulic connections if only one layer of tape is used. Apply tape carefully, two threads back, to prevent it from being pinched by the coupler and broken off inside the system. Loose pieces of sealant could travel through the system and obstruct the flow of fluid or cause jamming of precision-fit parts.

Storage

Store the unit in a dry, well-protected area where it will not be exposed to corrosive vapors, dust, or other harmful elements. If a unit has been stored for an extended period of time, it must be thoroughly inspected before it is used.

Checking Brushes on Electric Motors

To help prevent premature failure of the armature, check the brushes every 100 hours or 100,000 pressure cycles:

1. Remove the brush holder caps and brush assemblies.
2. The brush assemblies must be replaced if they are 4.7mm (3/16") long or less. See Figure 9.
3. Install brush assemblies and brush holder caps.

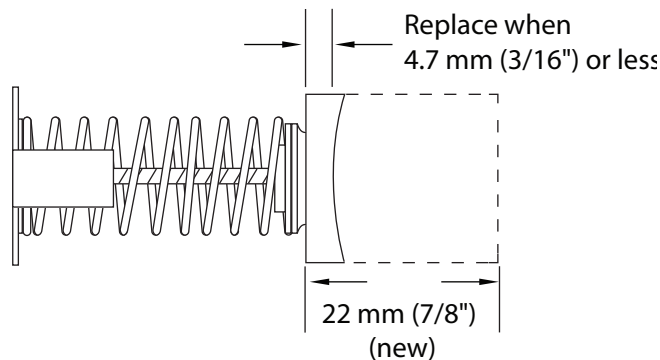

Figure 9. Brush Inspection

Troubleshooting Guide



WARNING:

- Repair work or troubleshooting must be performed by qualified personnel who are familiar with this equipment.
- Disconnect the power supply before removing the electrical cover. Electrical work should be performed by a qualified electrician.
- Check for system leaks by using a hand pump to apply pressure to the suspect area. Watch for leaking fluid and follow it back to its source. Never use your hand or other body parts to check for a possible leak.



Notes:

- For a detailed parts list or to locate a Power Team Authorized Hydraulic Service Center, contact your nearest Power Team facility.
- Plug the outlet ports of the pump when checking for leakage to determine if the leakage is in the pump, in the cylinder, or in the tool.

Problem	Cause	Solution
Electric motor does not run.	1. Pump not turned ON.	1. Position switch to RUN position.
	2. Unit is not plugged in.	2. Plug in unit.
	3. No voltage supply.	3. Check line voltage. Check reset button on power panel.
	4. Worn brushes.	4. Replace brushes.
	5. Circuit breaker tripped because total amperage draw too high for existing circuit.	5. Use an alternate circuit or have a qualified electrician add an additional circuit.
	6. Overheated motor (single-phase motor). Magnetic starter disengaged (three-phase motor). Thermal protector open.	6. Wait for motor to cool before restarting. Reset thermal protector. (Single-phase motor will reset automatically.)
	7. Faulty thermal protector (single-phase motor). Faulty magnetic starter (three-phase motor).	7. Replace defective parts.

Troubleshooting Guide continued

Problem	Cause	Solution
Electric motor will not shut off.	1. Defective motor controls.	<i>1. Disconnect unit from power supply; contact a Power Team Service Center.</i>
Electric motor stalls, surges, overheats, or will not start under load.	1. Low voltage	<i>1. Refer to electric motor information in Initial Setup section.</i>
	2. Electrical cord size too small.	<i>2. Refer to electrical cord chart in Initial Setup section.</i>
Electrical overload protector keeps tripping.	1. Wired incorrectly.	<i>1. Disconnect unit from power supply; have qualified electrician review motor and circuit wiring.</i>
Pump delivers excess fluid pressure.	1. Faulty pressure gauge.	<i>1. Replace gauge.</i>
	2. Relief valve set incorrectly.	<i>2. Contact a Power Team Service Center.</i>
Pump is not delivering fluid, or delivers only enough fluid to advance connected components partially or erratically or operation to slow.	1. Fluid level too low.	<i>1. Add fluid, refer to filling the pump reservoir in Initial Setup section.</i>
	2. Loose-fitting coupler to component.	<i>2. Verify quick-disconnect couplings to cylinders are completely coupled. Couplers may need to be replaced because ball check does not stay open due to wear.</i>
	3. Air in system.	<i>3. Refer to Initial Setup in this manual to bleed air from system.</i>
	4. Air leak in suction line.	<i>4. Check and tighten suction line.</i>
	5. Debris in pump or filter plugged.	<i>5. Clean pump filter. If problem persists, disconnect from power supply contact authorized Power Team service center.</i>
	6. Fluid bypasses through the double-acting cylinder.	<i>6. Remove cylinder; cap hoses. Check pump and valve for leaks.</i>
	7. Cold fluid or fluid too heavy. (Hydraulic fluid is of a higher viscosity than necessary.)	<i>7. Drain, flush, and refill reservoir using a lighter weight fluid. Refer to General Maintenance section.</i>
	8. External relief valve or low pressure unloading valve out of adjustment.	<i>8. Refer to Adjusting the Pressure Regulating Valve.</i>
	9. Power unit/reservoir capacity is too small for the size of the cylinder(s) used.	<i>9. Use smaller cylinder(s) or larger reservoir.</i>
	10. Vacuum in reservoir.	<i>10. Clean plugged vent in filler plug.</i>

Troubleshooting Guide continued

Problem	Cause	Solution
Pump builds pressure but cannot maintain pressure.	1. Fluid leakage.	<i>1. Look for external leaks. If no fluid leakage is visible, the problem is internal. If using a double-acting cylinder, remove it from the system to ensure the leak is not in the cylinder. Seal leaking pipe fittings with pipe sealant.</i>
	2. Leaking pressure switch seal.	<i>2. Replace pressure switch.</i>
Pump does not build to full pressure.	1. Faulty pressure gauge.	<i>1. Replace pressure gauge.</i>
	2. Check for external leakage.	<i>2. Seal faulty pipe fittings with pipe sealant.</i>
	3. Check external pressure regulator. Check relief valve setting.	<i>3. Refer to Adjusting the Pressure Regulating Valve.</i>
	4. Look for internal leakage in double-acting cylinders.	<i>4. Remove cylinder from pump. If pump builds full pressure, cylinder is defective.</i>
	5. Inadequate air pressure (air motor only).	<i>5. Refer to Initial Setup section.</i>
Erratic action	1. Air in system.	<i>1. Check for leaks. Refer to bleeding procedure.</i>
	2. Internal leakage in attached components.	<i>2. Refer to manufacture's information for attached component.</i>
	3. Attached component sticking or binding.	<i>3. Refer to manufacture's information for attached component.</i>
	4. Malfunctioning valve.	<i>4. Verify connections. Contact authorized Power Team Service Center.</i>

Power Team Facilities



UNITED
STATES

SPX Hydraulic Technologies
5885 11th Street
Rockford, IL 61109-3699
USA
Telephone: 1-815-874-5556
FAX: 1-815-874-7853

Cust. Service/Order Entry
Tel: 1-800-541-1418
FAX: 1-800-288-7031
E-mail:
info@powerteam.com

Technical Services
Tel: 1-800-477-8326
FAX: 1-800-765-8326

CHINA

No. 1568 Hua Shan Road
International Park Center
Shanghai 200052, China
Tel: 86 (21) 2208-5888
FAX: 86 (21) 2208-5682
E-mail
infochina@powerteam.com

FAR EAST

7 Gul Circle
Singapore 629563
Singapore
Tel: (65) 6265-3343
FAX: (65) 6265-6646
E-mail:
infoasia@powerteam.com

EUROPE

Albert Thijsstraat 12
6471 WX Eyselshoven
The Netherlands
Tel: 31 (45) 5678877
FAX: 31 (45) 5678878
E-mail
infoeurope@powerteam.com

For more information, Internet address: <http://www.powerteam.com>

