

Parts List for:

**NTW-PA464R
PA464R-RE**

AIR HYDRAULIC PUMP AIR MOTOR ASSEMBLY

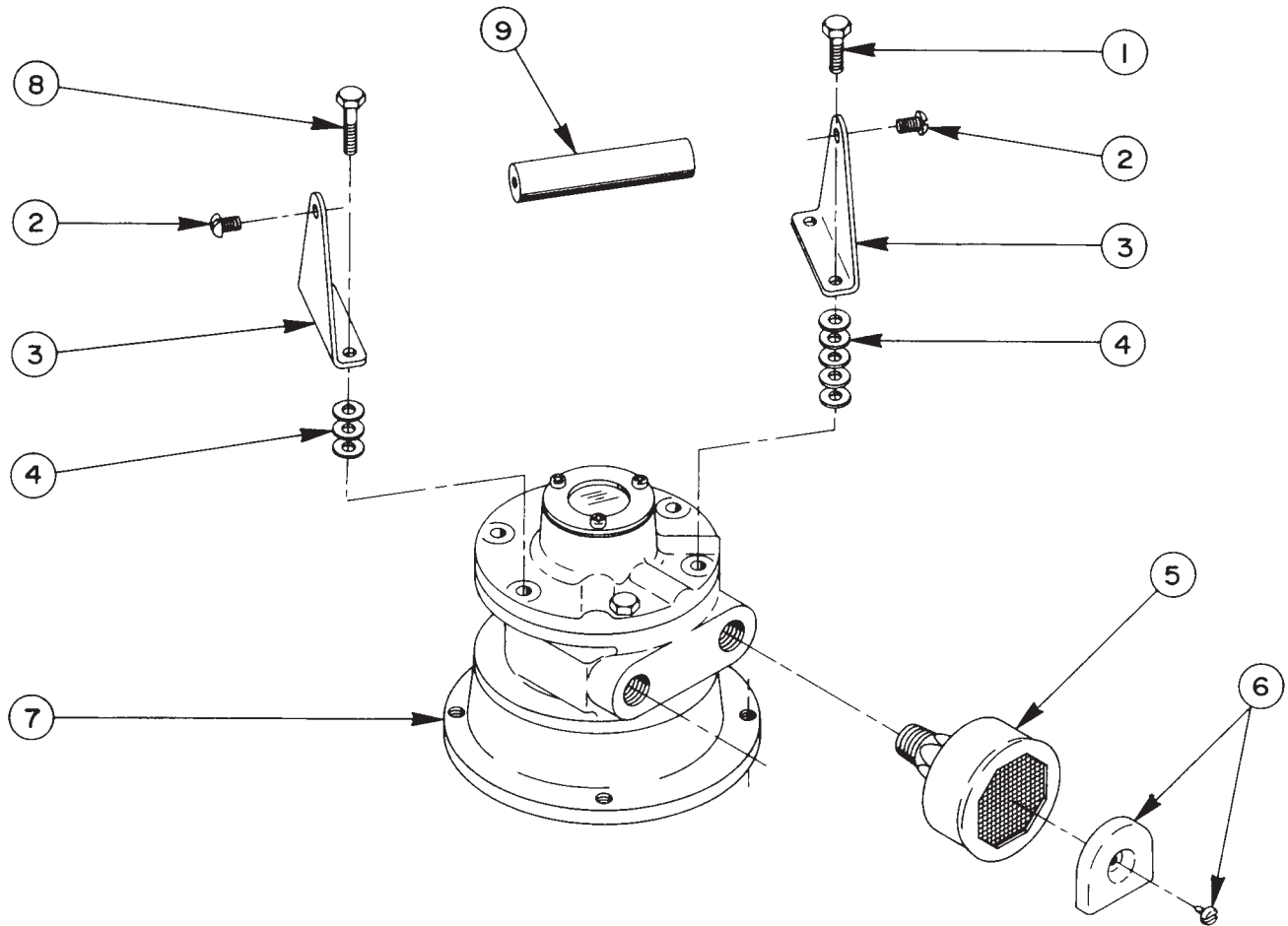

Item No.	Part No.	No. Req'd	Description
1	10014	1	Cap Screw (1/4-28 UNF X 1" Lg.)
2	10174	2	Machine Screw (1/4-20 UNC X 1/2 Lg.)
3	33808	2	Handle Bracket
4	12719	16	Washer (For 1/4 bolt)
5	13966	1	Muffler
6	205505	1	Deflector
7	*14717	1	Air Motor (For PA464R-RE)
	421502BK2	1	Air Motor (For NTW-PA464R)
8	10018	3	Cap Screw (3/8-16 X 3" Lg.)
9	28158	1	Handle

*Note: For air motor repair kit order no. 252100.

GENERAL ASSEMBLY

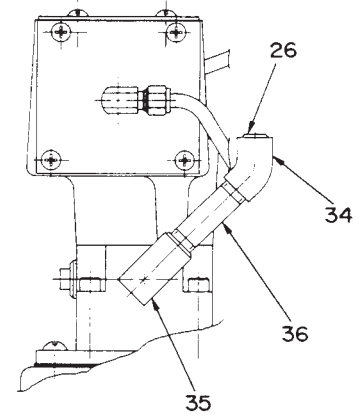
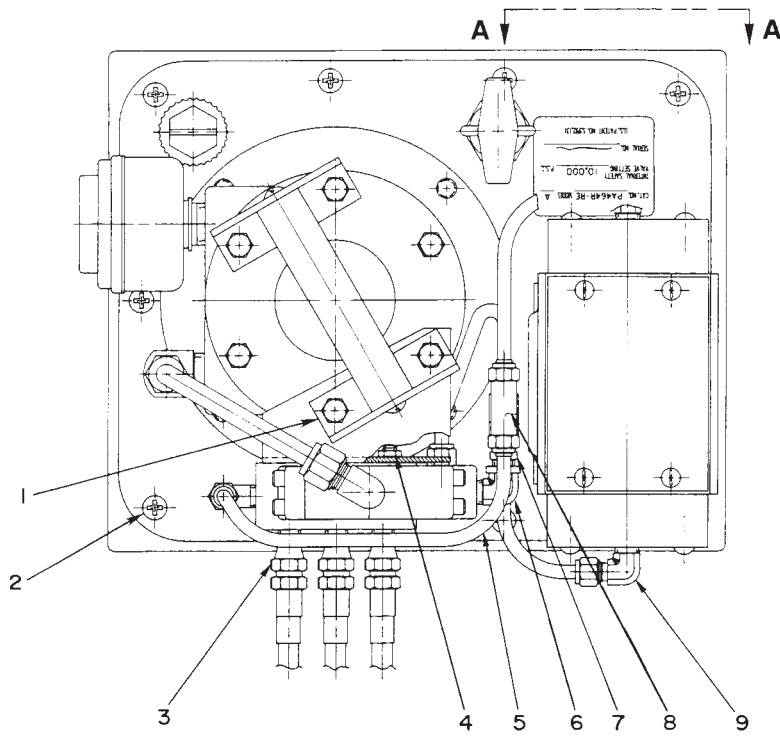

View AA

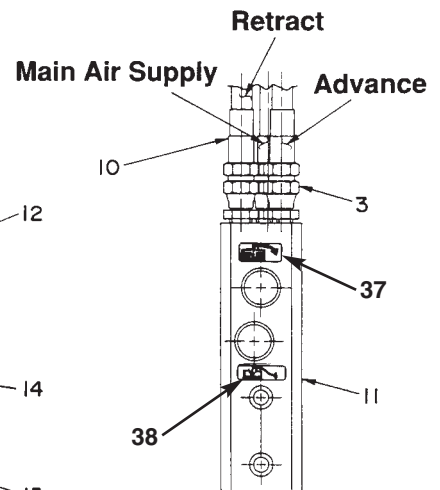
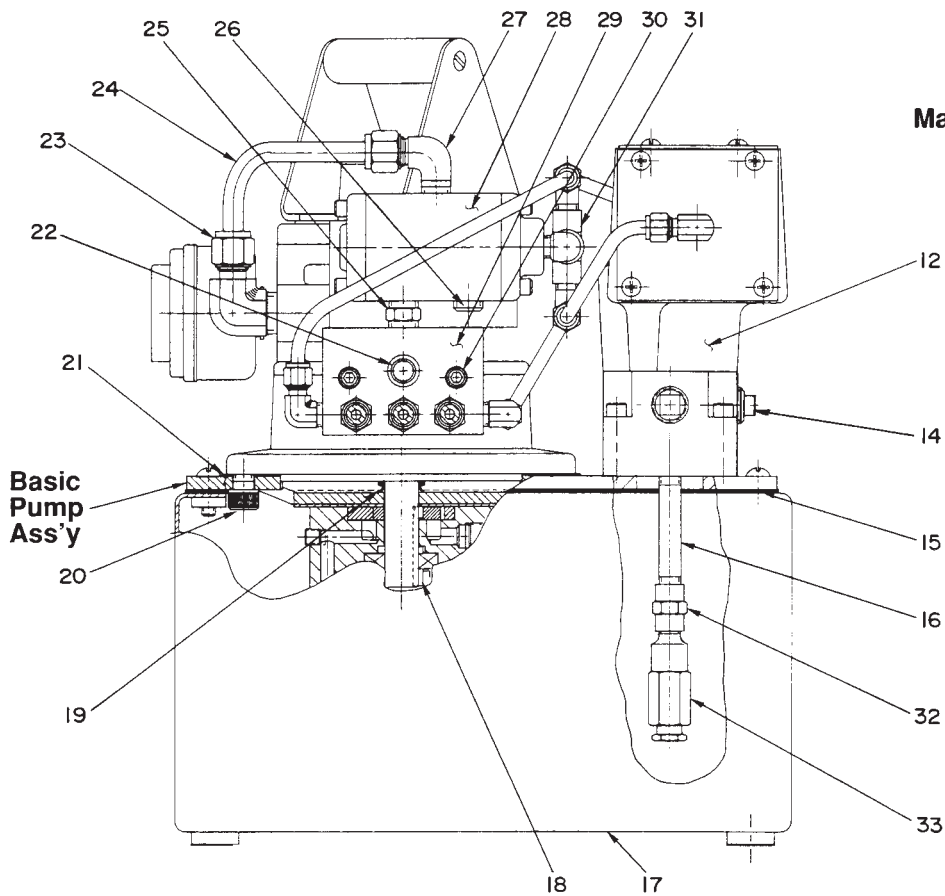

Item No.	Part No.	No. Req'd	Description
1	308675	1	Mounting Bracket
2	10177	10	Machine Screw (1/4-20 UNC X 3/4 Lg.)
3	208218	6	Straight Fitting
4	10199	2	Nut (1/4-20 UNC)
5	15883	2.3 ft.	Plastic Tubing
6	13229	1	90° Elbow Fitting
7	11421	1	Straight Fitting
8	15378	2	Tee Fitting
9	252653	4	90° Elbow Fitting
10	420096	1	Three Strand Hose Ass'y (25 feet)
11	421265	1	Air Operated Hand Control (See Form #100426)
12	9594	1	Valve Assembly (See Form #108068)
14	13272	2	Plastic Plug
15	40164	1	Cover Plate Gasket (1/16 thick)
16	15456	1	Nipple Fitting
17	214097	1	Key
18	40063OR9	1	Reservoir (For PA464R-RE)
	40063BK2	1	Reservoir (For NTW-PA464R)
19	213674	1	O-ring
20	15187	4	Cap Screw (3/8-16 UNC X 5/8 Lg.; Torque to 90/100 in. lbs.)
21	307425	1	Motor Gasket
22	14794	1	Plastic Cap
23	17636	1	90° Fitting
24	215639	1	Copper Tubing
25	16494	1	Straight Fitting
26	10479	2	Pipe Plug (1/4 NPTF)
27	10665	1	90° Elbow Fitting
28	212404	1	Air Operated Valve
29	37593	1	Air Manifold Block
30	10022	2	Cap Screw (1/4-20 UNC X 1-1/2 Lg.)
31	212405	1	Shuttle Valve
32	18841	1	Connector Fitting
33	21278-10	1	Relief Valve (For PA464R-RE; Set at 900/1,100 PSI)
	21278-15	1	Relief Valve (For NTW-PA464R; Set at 1,500/1,700 PSI)
34	104506	1	45° Elbow Fitting
35	10617	1	90° Elbow Fitting
36	9684	1	Nipple Fitting
37	251759	1	Instruction Decal (Pump)
38	251760	1	Instruction Decal (Release)

Note: Shaded areas reflect last revision(s) made to this form.

BASIC PUMP ASSEMBLY

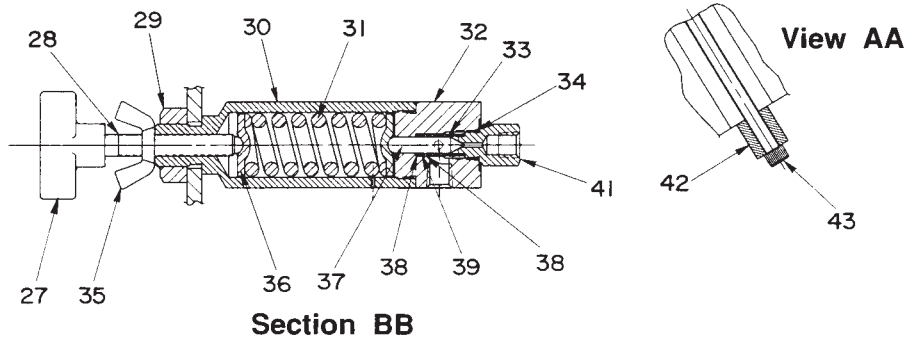
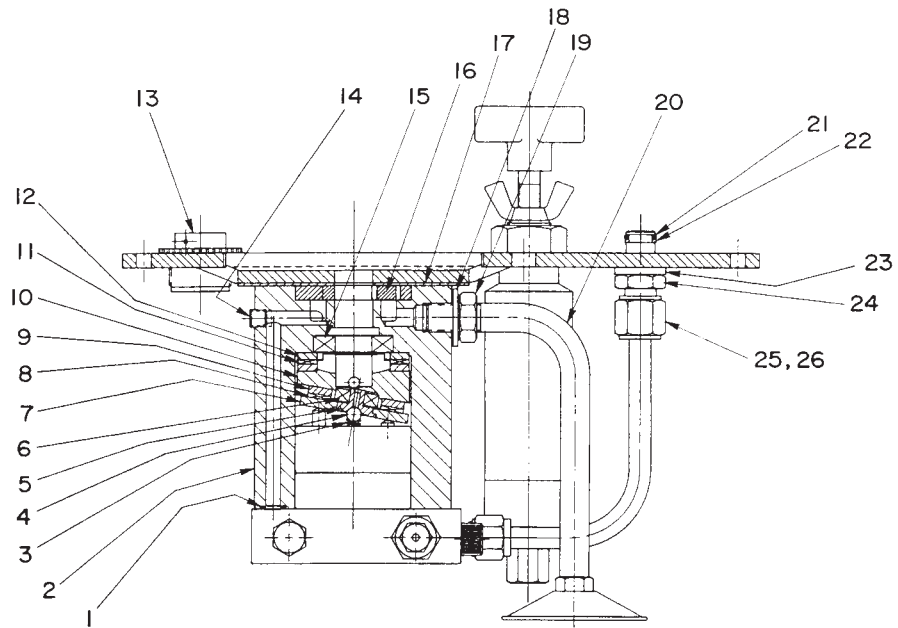

Cross torque
in 20/30 in. lbs. increments
in order shown.

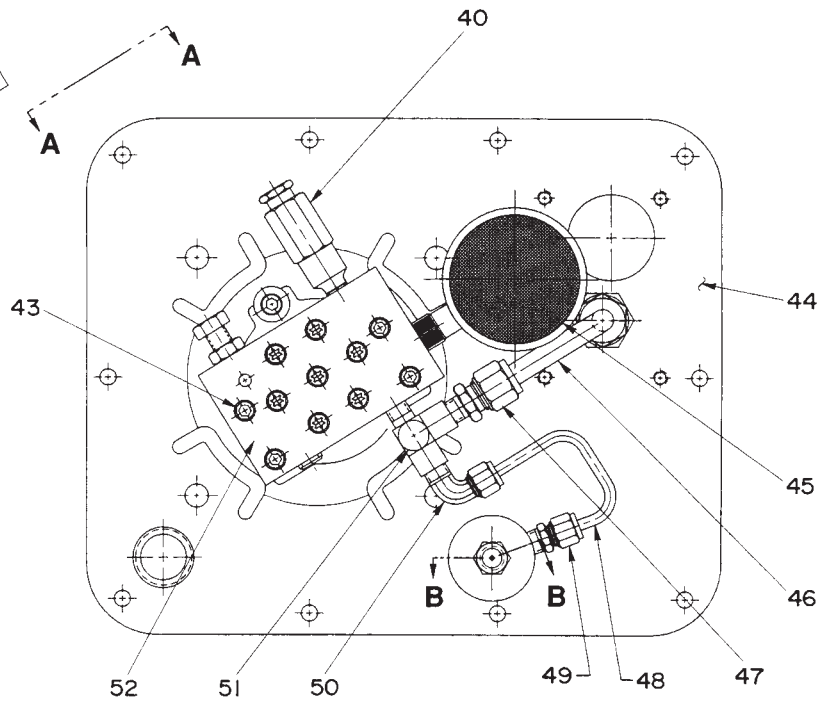
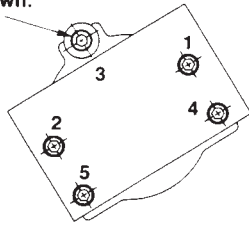

Item No.	Part No.	No. Req'd	Description	Item No.	Part No.	No. Req'd	Description
1	10267	1	O-ring (7/16 X 5/16 X 1/16)	26	308614	1	Oil Line Tube
2	52883	1	Pump Body	27	215693	1	Plastic Knob
3	16320	1	Compression Spring (1/4 O.D. X 3/4 Lg.)	28	215721	1	Adjustment Stem
4	10375	1	Steel Ball (1/4 Dia.)	29	10396	1	Jam Nut (3/4-16)
5	23547	1	Bearing Top Plate	30	309077	1	Regulator Housing
6	11814	1	Ball Bearing	31	215429	1	Compression Spring (1.100 O.D. X 2-1/2 Lg.)
7	23548	1	Top Plate	32	47648	1	Regulator Body
8	15431	1	Needle Thrust Bearing	33	215431	1	Sleeve (Position holes towards packings)
9	15432	1	Bearing Race	34	13755	1	O-ring (.558 X .414. X .072)
10	35271	1	Angle Plate	35	215683	1	Wing Nut (3/8-24)
11	11228	1	Needle Thrust Bearing	36	215428	2	Retainer Spring
12	11227	2	Bearing Race	37	309079	1	Poppet
13	213706	1	Filler Cap	38	215430	2	Backup Washer (3/8 X 1/4 X 1/16)
14	11084	1	Pipe Plug (1/16 NPTF; Torque to 35/45 in. lbs. oiled)	39	10266	1	O-ring (3/8 X 1/4 X 1/16)
15	15695	1	Ball Bearing	40	21278	1	Relief Valve (Set at 10,100/10,700 PSI)
16	15693	1	Gerotor Set	41	309078	1	Seat Fitting
17	307296	1	Wear Plate	42	214720	1	Spacer
18	213709	1	Seal Washer (Turn on; do not push on)	43	15642	5	Cap Screw (1/4-20 X 5" Lg.; Torque to 55/65 in. lbs.)
19	10390	1	Jam Nut (1/2-20 UNF)	44	47404BK2	1	Reservoir Cover
20	213686	1	Intake Tube	45	29682	1	Strainer/Filter
21	10268	2	O-ring (1/2 X 3/8 X 1/16)	46	214930	1	Oil Line Tube
22	11863	1	Backup Washer (1/2 X 3/8 X 1/16)	47	12696	1	Straight Fitting
23	21484	1	Spacer	48	215674	1	Regulator Oil Line Ass'y
24	214882	1	Connector Valve (Torque valve connector [214882] to 20/30 ft. lbs. into coverplate [47404]; hold valve conector [214882] & torque tube nut [10431] to 40/50 ft. lbs.)	49	14844	1	Straight Fitting
25	10430	1	Tube Sleeve	50	16177	1	90° Fitting
26	10431	1	Tube Nut	51	18969	1	Tee Fitting
27	215693	1	Plastic Knob	52	36922	1	High Pressure Pump Ass'y (See back sheet 3 of 4)

Refer to any operating instructions included with this product for detailed information about operation, testing, disassembly, reassembly, and preventive maintenance.

Items found in this parts list have been carefully tested and selected. **Therefore: Use only genuine Power Team replacement parts!**

Additional questions can be directed to our Technical Services Department.

HIGH PRESSURE PUMP ASSEMBLY

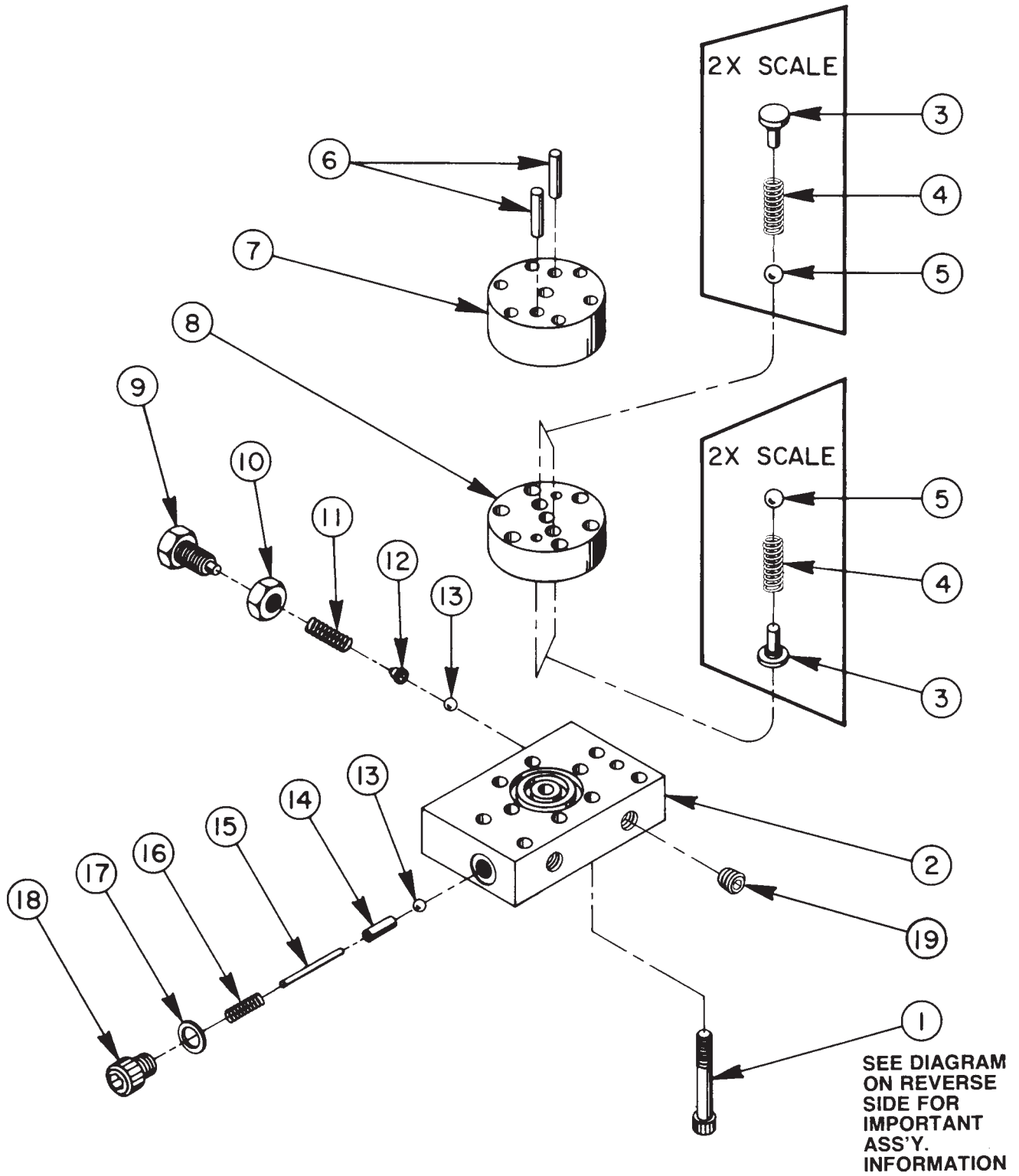

Item No.	Part No.	No. Req'd	Description
1	*16747	7	Torx Drive Cap Screw (1/4-28 X 1-3/4 Lg.; See diagram below)
2	*36912	1	Pump End Plate
3	*24549	4	Valve Guide
4	*10445	4	Compression Spring (5/32 O.D. X 3/4 Lg.)
5	*12223	4	Steel Ball (3/16 Dia.)
6	*20775	2	Piston
7	*41006	1	Pump Barrel
8	*41007	1	Valve Head
9	200797	1	Adjusting Screw
10	10386	1	Jam Nut (3/8-24)
11	15691	1	Compression Spring (1/4 O.D. X 5/8 Lg.)
12	200796	1	Spring & Ball Adapter
13	10375	2	Steel Ball (1/4 Dia.)
14	201998	1	Sleeve
15	12571	1	Roll Pin (1/8 Dia. X 1-3/8 Lg.)
16	14431	1	Compression Spring (3/16 O.D. X 3/4 Lg.)
17	12042	1	Copper Washer (9/16 X 3/8 X 1/32 Thk.)
18	29690	1	Cap Screw (Torque to 180 in. lbs.)
19	10427	1	Pipe Plug (1/8 NPTF)

Consult factory when replacing items marked with an asterisk (*).

BOLT TIGHTENING SEQUENCE

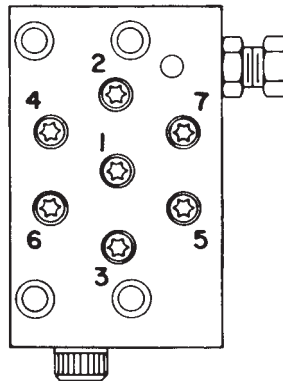

NOTE: Assemble in sequence shown. Lubricate under head and on threads. Torque to 170 in lbs.

HYDRAULIC SCHEMATIC

