

MODEL B (Model C for PE102A-GRC) ELECTRIC HYDRAULIC PUMP Max. Capacity: 10,000 PSI

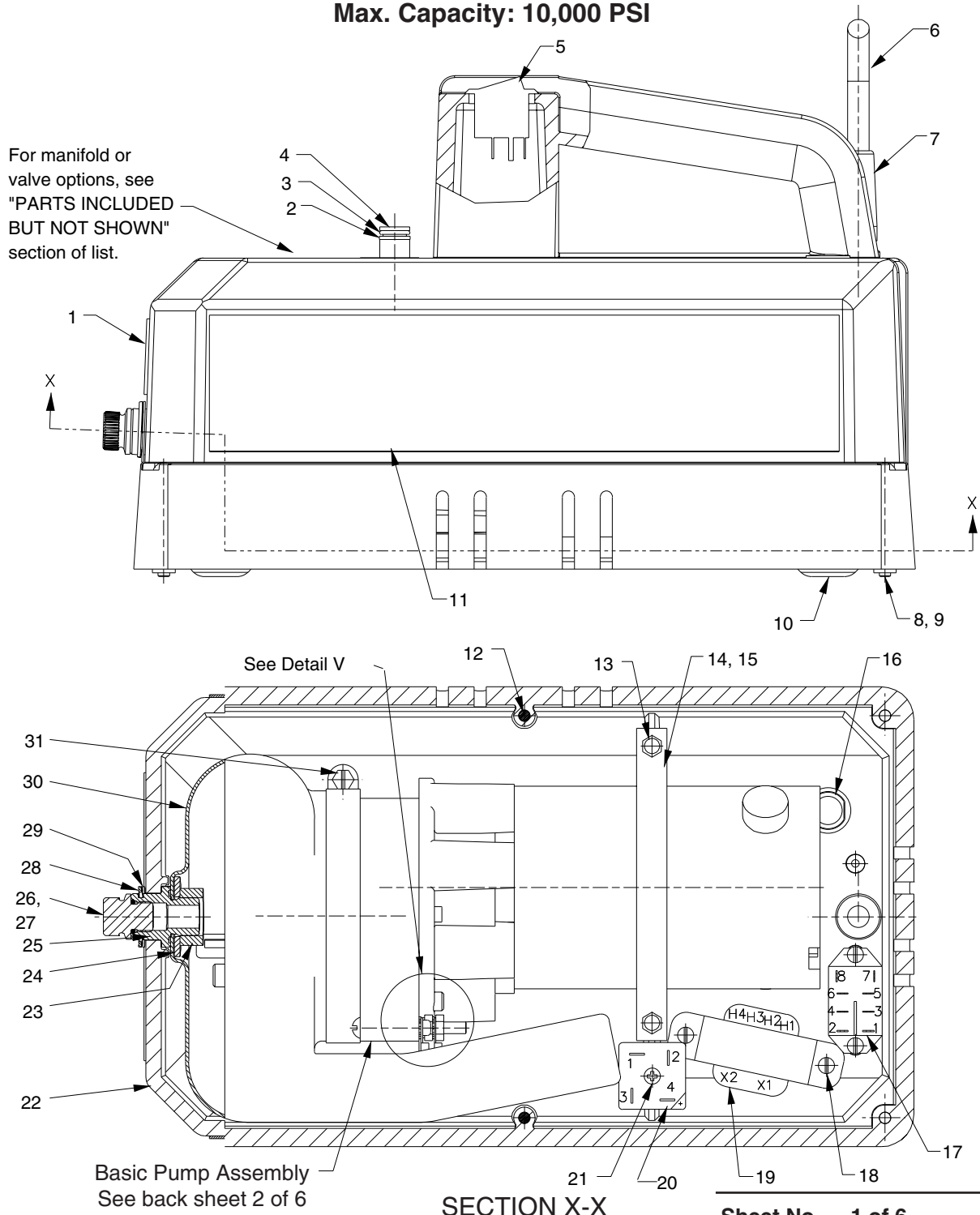

Parts List, Form No. 101703, Back sheet 1 of 6

| Item No. | Part No. | No. Req'd | Description |
|----------|----------|-----------|--|
| 1 | 251072 | 1 | Warning & Fill Instructions Decal |
| 2 | *11863 | 2 | Backup Washer (1/2 X 3/8 X 1/16) |
| 3 | *10268 | 2 | O-ring (1/2 X 3/8 X 1/16; For PE102, PE102-220, PE104, PE104-220, PR102 & PR104) |
| | †17716 | 2 | O-ring (1/2 X 3/8 X 1/16; For PE102, PE102-220, PE104, PE104-220, PR102 & PR104) |
| | *10268 | 3 | O-ring (1/2 X 3/8 X 1/16; For PE102A, PE102A-220 & PR102A) |
| | †17716 | 3 | O-ring (1/2 X 3/8 X 1/16; For PE102A, PE102A-220 & PR102A) |
| 4 | 202505 | 1 | Bushing (For PE102, PE102A, PE102-220, PE102A-220, PR102 & PR104) |
| | 251128 | 1 | Bushing (For PE104, PE104-220 & PR104) |
| 5 | 251051 | 1 | Rocker Switch |
| 6 | 24733 | 1 | Cord Set (For PE Series only) |
| | 250894 | 1 | Electrical Plug (For PR Series only) |
| | 12293 | 1.5 ft. | Electrical Cable (For PR Series only) |
| 7 | 251048 | 1 | Bushing |
| 8 | 12515 | 4 | Machine Screw (10-24 UNC X 1 3/4 Lg.) |
| 9 | 207405 | 4 | Locknut (10-24 UNC) |
| 10 | 420607 | 1 | Base Plate |
| 11 | 350672 | 2 | Trade Name Decal (For PR Series) |
| | 351035 | 2 | Trade Name Decal (For PE Series) |
| | 252102 | 2 | Trade Name Decal (For LUKAS) |
| 12 | 14456 | 2 | Screw (#10-24 X 1/2 Lg.; Place ground wire terminal between cover & housing.) |
| 13 | 211060 | 2 | Screw (#9-15 X 1" Lg.) |
| 14 | 251039 | .5 ft. | Motor Mounting Strap |
| 15 | 251041 | 3" | Channel Rubber |
| 16 | 251045 | 1 | "D" Bushing Plug |
| 17 | 251046 | 1 | Relay (For PE Series only) |
| 18 | 15468 | 4 | Screw (#6-32 X 3/8 Lg.) |
| 19 | 251049 | 1 | Transformer (For PE Series only) |
| | 251052 | 1 | Relay (For PR Series only) |
| 20 | 251050 | 1 | Rectifier (For PE Series only) |
| 21 | 251073 | 1 | Screw (6-32 x 3/4 Lg.; For PE Series only) |
| 22 | 64363 | 1 | Plastic Housing |
| | 64616 | 1 | Plastic Housing (For PE102AR & PE102AR-220) |
| 23 | 10394 | 1 | Hex Nut (5/8-18 UNF) |
| 24 | 13324 | 1 | Washer (For 5/8 Bolt) |
| 25 | 350583 | 1 | Filler Adapter |
| 26 | *13755 | 1 | O-ring (.558 x .414 x .072) |
| | †251035 | 1 | O-ring (.558 x .414 x .072) |
| 27 | 251280 | 1 | O-ring Boss Plug |
| 28 | 251043 | 1 | Retaining Ring |
| 29 | 201373 | 1 | Retainer Washer |

| Item No. | Part No. | No. Req'd | Description |
|----------|----------|-----------|----------------|
| 30 | 420643 | 1 | Bladder |
| | †420736 | 1 | Bladder |
| 31 | 350305 | 1 | Hose Clamp |
| 32 | 2001397 | 1 | Bladder Spacer |

PARTS INCLUDED BUT NOT SHOWN

| | | |
|---------|---|--|
| †250238 | 1 | Decal (EPR Seals) |
| 350646 | 1 | Cord Set (For PR Series only) |
| 10855 | 2 | Screw (Torque to 160/180 in. lbs. Tighten the screw on the right hand side facing the pump first.) |
| *10268 | 1 | O-ring (1/2 X 3/8 X 1/16; For PE102A, PE102A-220, & PR102A) |
| †17716 | 1 | O-ring (1/2 X 3/8 X 1/16; For PE102A, PE102A-220, & PR102A) |
| 251253 | 1 | Remote Switch (For PR102A-DEUT) |
| 251635 | 1 | Remote Switch (For PE102A-EMP) |
| 251048 | 1 | Bushing (For units equipped with a remote switch) |
| 250176 | 1 | Fuse (For PE102, PE102A, & PE104) |
| 206962 | 1 | Fuse (For PE102-220, PE102A-220, & PE104-220) |
| 251561 | 1 | Receptacle (For PE102AR & PE102AR-220) |
| 14456 | 2 | Screws (#10-24 X 1/2 Lg.; For PE102AR & PE102AR-220) |

OTHER OPTIONS AND ACCESSORIES

| | | |
|--------|---|---|
| 9562 | 1 | Manifold (For PE102A, PE102A-220, PR102A, PE102A-EMP & PR102A-DEUT; See Form No. 101344) |
| 9561 | 1 | 2 Position, 2-Way Valve (For PE102, PE102-220, PE102A-EMP, PR102A-DEUT & PR102; See Form No. 101327) |
| 9563 | 1 | 3 Position, 4-Way Valve (For PE104, PE104-220, & PR104; See Form No. 101326) |
| 9560 | 1 | Pressure Regulator (For PE102-ANCHOR; See Form No. 101328) |
| 10461 | 1 | Foot Switch Assembly |
| 25017 | 1 | Hand Switch Assembly |
| 9625 | 1 | Pressure Switch (See Form No. 100589) |
| BP12V | 1 | 12 Volt Battery Pack (Includes sealed lead acid battery, 115 V. charger, battery-to-pump 4 ft. cord set, carrying case and shoulder strap.) |
| VC220 | 1 | Voltage Converter w/ Plug Adapters (Converts 220 V. 50/60 cycle to 110 V. 50/60 cycle) |
| RB12V | 1 | Replacement Battery only |
| RC12V | 1 | Replacement Battery 4 Ft. Cord Set (For BP12V) |
| 351240 | 1 | Manifold (For PE102-28-DC & PE102-28-220DC) |
| 351845 | 1 | Electrical Plug (For LUKAS) |

Part numbers marked with an asterisk (*) are contained in Repair Kit No. 300651.
Part numbers marked with a dagger (†) are contained in EPR Seal Kit No. 300653.

NOTE: For LUKAS brand pumps, if additional parts (that are not shown here) need replacing, contact your nearest LUKAS service center.

**DETAIL FOR 4-WAY VALVE OUTLET CHECK
(FOR PE104, PE104-220, & PR104)**

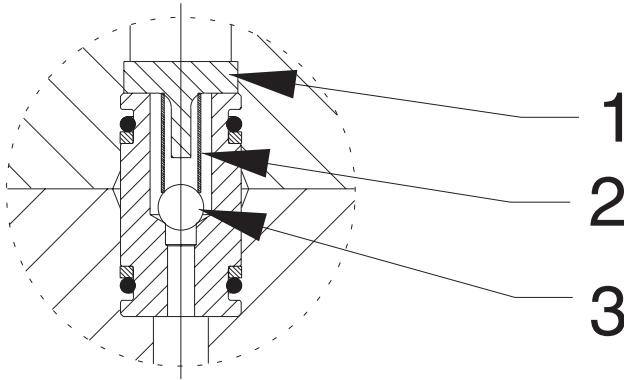

| Item No. | Part No. | No. Req'd | Description |
|----------|----------|-----------|---|
| 1 | 209795 | 1 | Outlet Ball Stop |
| 2 | *10445 | 1 | Compression Spring (5/32 O.D. X 3/4 Lg.) |
| 3 | *12223 | 1 | Ball (3/16 Dia.) |

Part numbers marked with an asterisk (*) are contained in Repair Kit No. 300653.

DETAIL V

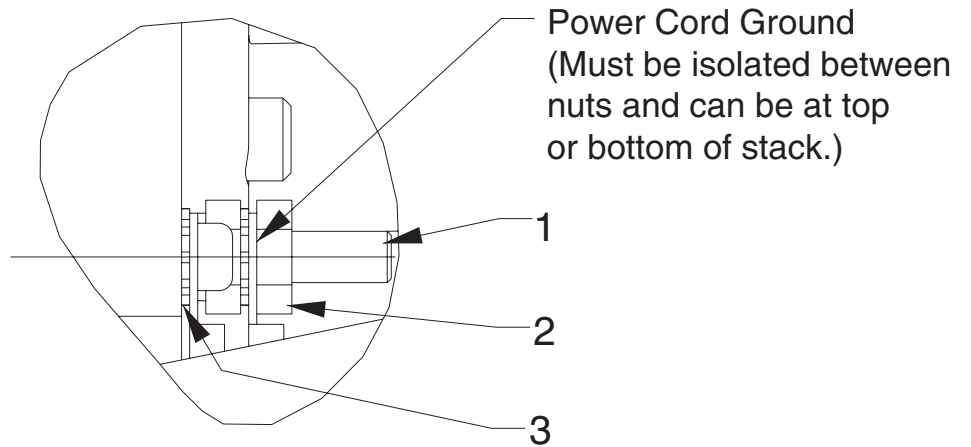

Grd

Note: Serrated lockwasher must be adjacent to pump body.

| Item No. | Part No. | No. Req'd | Description |
|----------|----------|-----------|---|
| 1 | 12515 | 1 | Machine Screw (#10-24 UNC X 3/4 Lg.) |
| 2 | 10197 | 2 | Nut (#10-24 UNC) |
| 3 | 11108 | 2 | Lockwasher (#10 External Tooth) |

BASIC PUMP ASSEMBLY

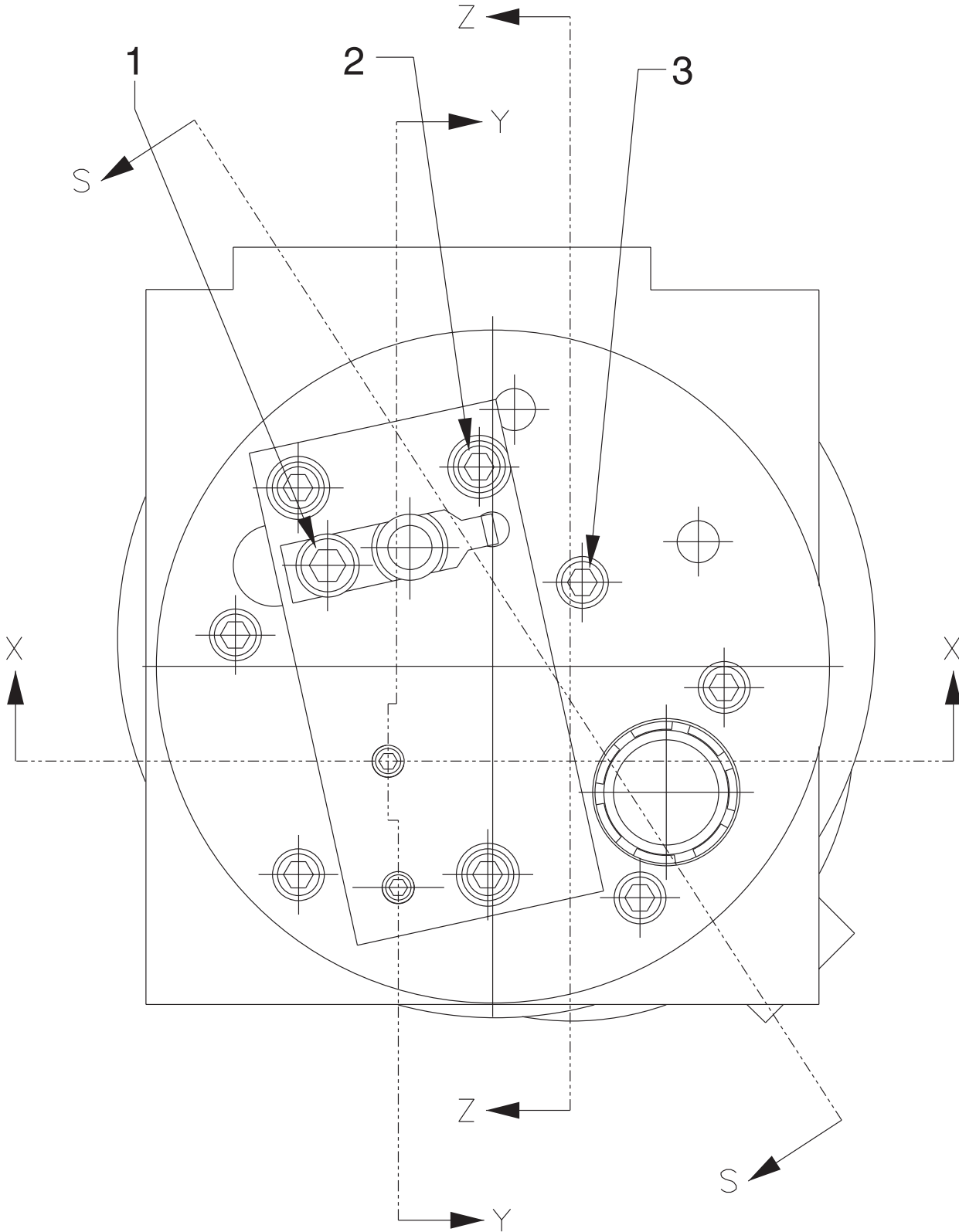

| Item No. | Part No. | No. Req'd | Description |
|----------|----------|-----------|---|
| 1 | 10002 | 1 | Screw (1/4-20 UNC X 3/8 Lg.; Torque to 80/100 in. lbs.) |
| 2 | 14423 | 3 | Screw (#10-24 X 2" Lg.; Torque to 60/80 in. lbs.) |
| 3 | 14426 | 5 | Screw (#10-24 UNC X 1" Lg.; Torque to 60/80 in. lbs.) |

SECTION X-X

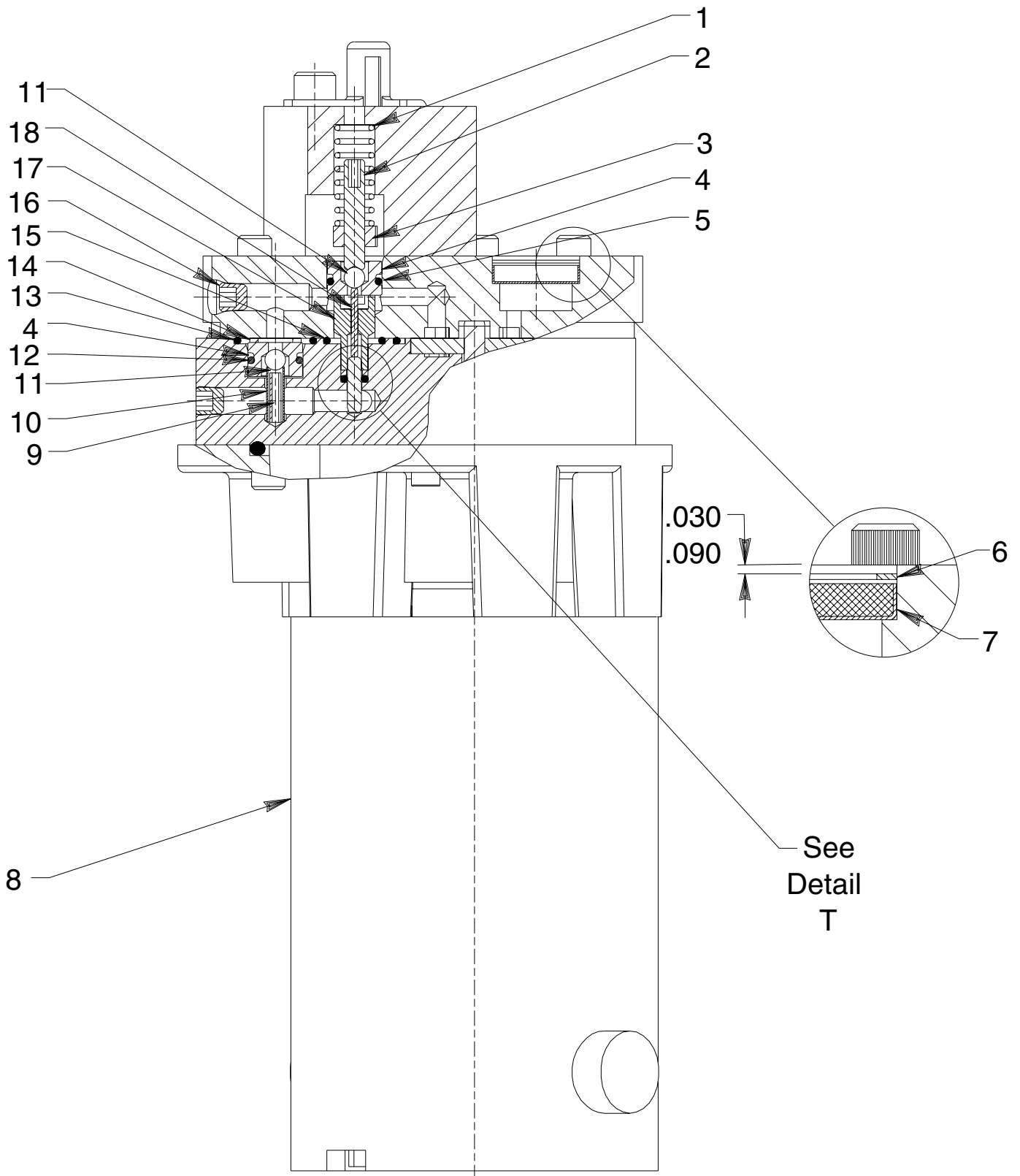

Parts List, Form No. 101703, Back sheet 3 of 6

| Item No. | Part No. | No. Req'd | Description |
|----------|------------|-----------|--|
| 1 | *14484 | 1 | Compression Spring (3/8 O.D. X 1" Lg.) |
| 2 | *251067 | 1 | Set Screw (#10-24 UNC x 1" Lg. Set unloading valve to 400/500 PSI) |
| 3 | *207405 | 1 | Locknut (10-24 UNC) |
| 4 | *251065 | 1 | Replaceable Seat |
| 5 | *10268 | 1 | O-ring (1/2 X 3/8 X 1/16) |
| | †17716 | 1 | O-ring (1/2 X 3/8 X 1/16) |
| 6 | *16686 | 1 | Retaining Ring (Internal) |
| 7 | *214578 | 1 | Filter |
| 8 | 421297-110 | 1 | Motor (For PE102, PE102A, & PE104; For replacement brush assembly, order [2] #251114-110) |
| | 421297-220 | 1 | Motor (For PE102-220, PE102A-220, & PE104-220; For replacement brush assembly, order [2] #251114-220) |
| | 421297-12 | 1 | Motor (For PR102, PR102A, & PR104; For replacement brush assembly, order [2] #251114-12) |
| 9 | 11512 | 1 | Roll Pin |
| 10 | *15141 | 1 | Compression Spring (3/16 O.D. X 5/8 Lg.) |
| 11 | *12223 | 2 | Ball (3/16 Dia.) |
| 12 | *13943 | 1 | O-ring (1/2 X 3/8 X 1/16) |
| | †17716 | 1 | O-ring (1/2 X 3/8 X 1/16) |
| 13 | *10302 | 1 | O-ring (3/4 X 5/8 X 1/16) |
| | †12400 | 1 | O-ring (3/4 X 5/8 X 1/16) |
| 14 | *11031 | 1 | Copper Washer (15/32 X 5/16 X 1/32) |
| 15 | *12098 | 1 | O-ring (9/16 X 7/16 x 1/16) |
| | †250136 | 1 | O-ring (9/16 X 7/16 x 1/16) |
| 16 | 15130 | 3 | Plug (1/16 NPTF) |
| 17 | 251068 | 1 | Guide |
| 18 | 13937 | 1 | Dowel Pin |

Part numbers marked with an asterisk (*) are contained in Repair Kit No. 300651.
Part numbers marked with a dagger (†) are contained in EPR Seal Kit No. 300653.

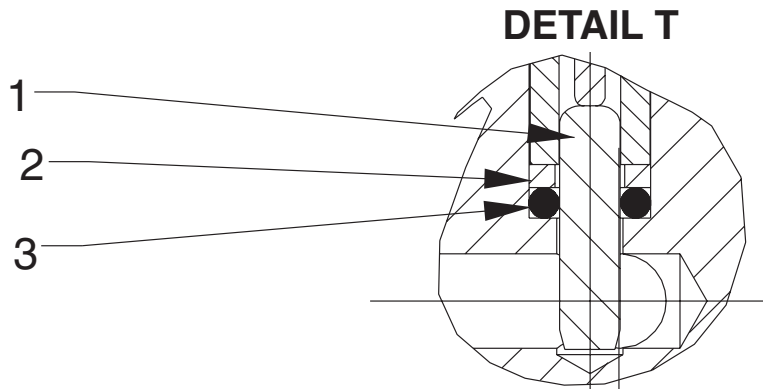

| Item No. | Part No. | No. Req'd | Description |
|----------|----------|-----------|------------------------------------|
| 1 | 10796 | 1 | Dowel Pin |
| 2 | *214992 | 1 | Backup Washer (15/64 x 1/8 x 3/64) |
| 3 | *17797 | 1 | O-ring (1/4 X 1/8 X 1/16) |
| | †17713 | 1 | O-ring (1/4 X 1/8 X 1/16) |

Part numbers marked with an asterisk (*) are contained in Repair Kit No. 300651.
Part numbers marked with a dagger (†) are contained in EPR Seal Kit No. 300653.

SECTION Y-Y

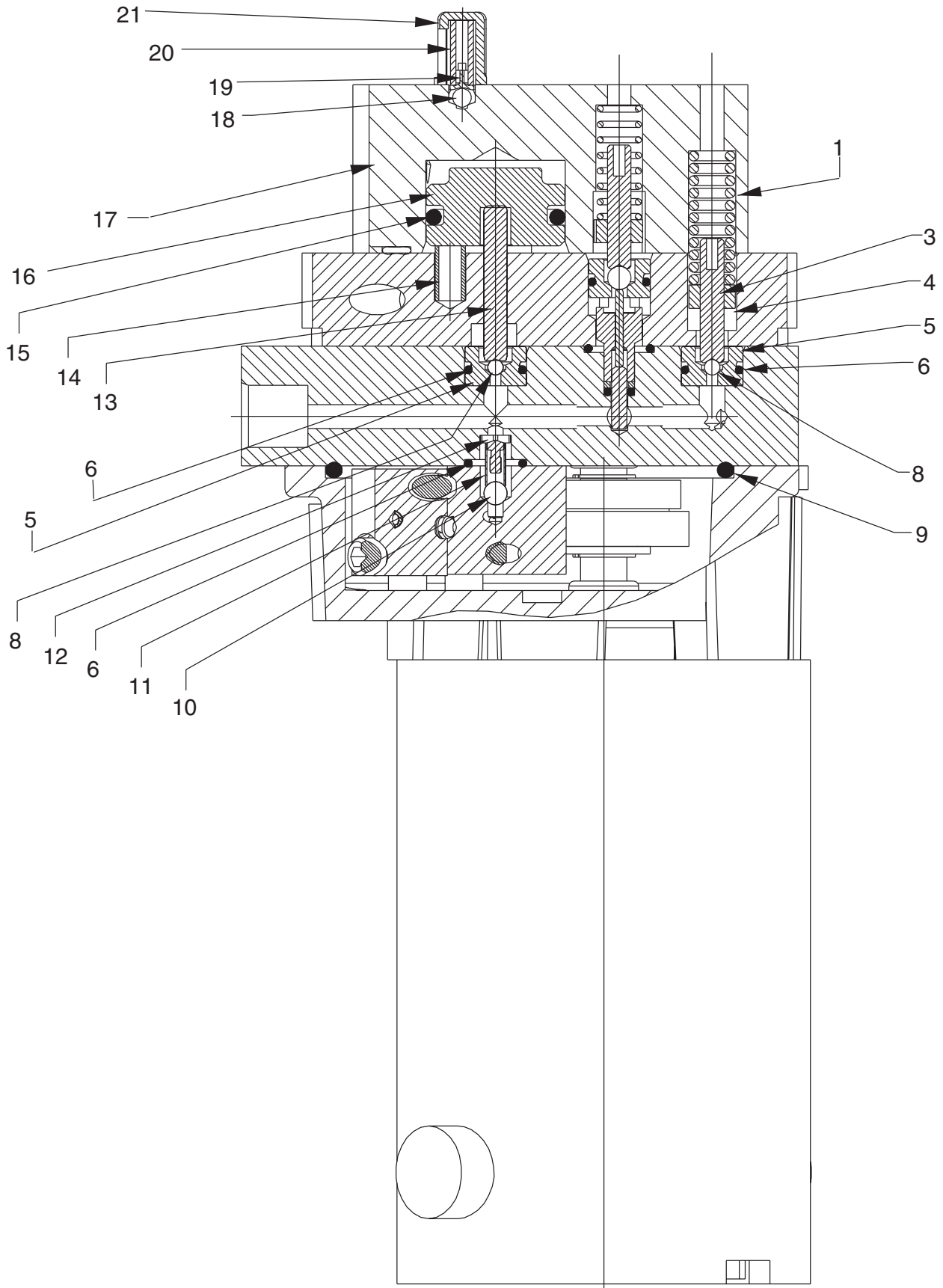

Parts List, Form No. 101703, Back sheet 4 of 6

| Item No. | Part No. | No. Req'd | Description |
|----------|----------|-----------|---|
| 1 | *16724 | 1 | Compression Spring (3/8 O.D. x 1-1/4 Lg.) |
| 3 | *251067 | 1 | Set Screw (#10-24 UNC x 1" Lg.; Set High Pressure Relief Valve to 10,100/10,700 PSI [2,800/3,200 PSI for PE102-28-DC & PE102-28-220DC]) |
| 4 | *207405 | 1 | Locknut (10-24 UNC) |
| 5 | *251064 | 2 | Replaceable Seat |
| 6 | *13943 | 3 | O-ring (1/2 X 3/8 X 1/16) |
| | †17716 | 3 | O-ring (1/2 X 3/8 X 1/16) |
| 8 | *10418 | 2 | Steel Ball (1/8 Dia.) |
| 9 | *10297 | 1 | O-ring (3-1/2 X 3 -1/4 X 1/8) |
| | †13454 | 1 | O-ring (3-1/2 X 3 -1/4 X 1/8) |
| 10 | *12223 | 1 | Ball (3/16 Dia.) |
| 11 | *10445 | 1 | Compression Spring (5/32 O.D. X 3/4 Lg.) |
| 12 | 24549 | 1 | Ball Guide |
| 13 | *251083 | 1 | Dowel Pin |
| 14 | *11024 | 3 | Compression Spring (1/4 O.D. X 5/8 Lg.) |
| 15 | *19029 | 1 | O-ring (1-1/8 x 15/16 x 1/8) |
| | †251288 | 1 | O-ring (1-1/8 x 15/16 x 1/8) |
| 16 | 350619 | 1 | Eccentric |
| 17 | 420616 | 1 | Automatic Valve Body |
| 18 | *10374 | 1 | Steel Ball (7/32 Dia.) |
| 19 | 200796 | 1 | Adapter |
| 20 | *15691 | 1 | Compression Spring (1/4 O.D. X 5/8 Lg.) |
| 21 | 350577 | 1 | Spring Retainer |

Part numbers marked with an asterisk (*) are contained in Repair Kit No. 300651.
 Part numbers marked with a dagger (†) are contained in EPR Seal Kit No. 300653.

Refer to any operating instructions included with this product for detailed information about operation, testing, disassembly, reassembly, and preventive maintenance.

Items found in this parts list have been carefully tested and selected. **Therefore: Use only genuine Power Team replacement parts!**

Additional questions can be directed to our Technical Services Department.

SECTION Z-Z

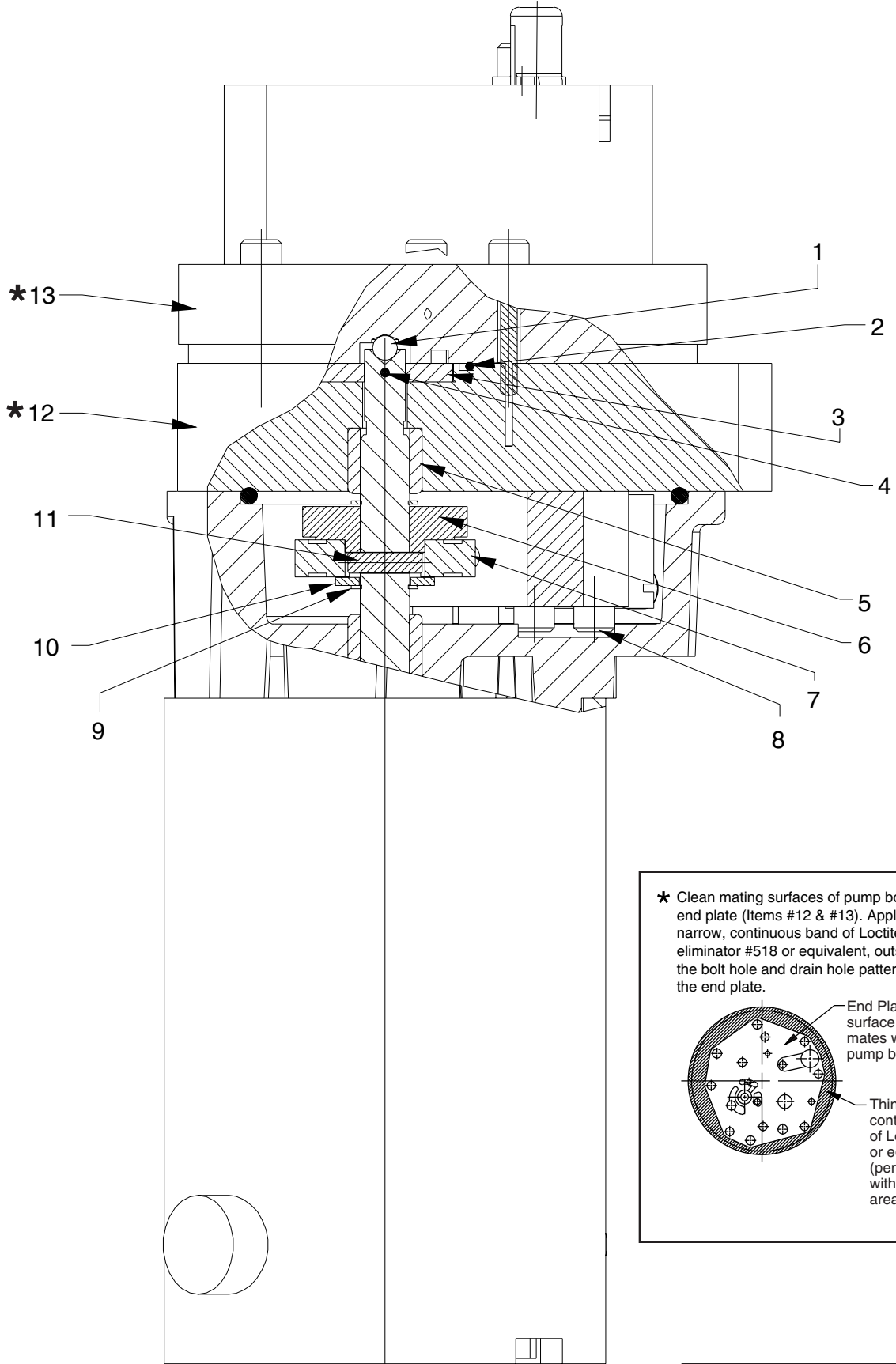

★ Clean mating surfaces of pump body and end plate (Items #12 & #13). Apply a thin, narrow, continuous band of Loctite gasket eliminator #518 or equivalent, outside of the bolt hole and drain hole patterns on the end plate.

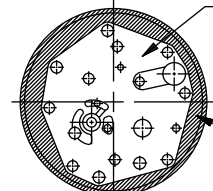

End Plate surface that mates with the pump body

Thin, narrow continuous band of Loctite #518 or equivalent (permissible within shaded area.)

| Item No. | Part No. | No. Req'd | Description |
|----------|----------|-----------|---|
| 1 | *12223 | 1 | Ball (3/16 Dia.) |
| 2 | *251063 | 1 | O-ring (1-7/16 x 1-5/16 x 1/16) |
| | †251289 | 1 | O-ring (1-7/16 x 1-5/16 x 1/16) |
| 3 | 420615 | 1 | Gerotor Set |
| 4 | 251061 | 1 | Dowel Pin |
| 5 | 251129 | 1 | Needle Bearing |
| 6 | 350606 | 1 | Eccentric |
| 7 | 15695 | 1 | Ball Bearing |
| 8 | 250491 | 4 | Screw (10-24 UNC x 1-1/4 Lg.; Torque to 60/80 in. lbs.) |
| 9 | 251069 | 2 | Retaining Ring (Internal) |
| 10 | 252169 | 1 | Washer (25/64 X 3/4 X 1/16) |
| 11 | 251117 | 1 | Spring Pin |
| 12 | 64347 | 1 | End Plate |
| 13 | 64346 | 1 | Pump Body |

Part numbers marked with an asterisk (*) are contained in Repair Kit No. 300651.
 Part numbers marked with a dagger (†) are contained in EPR Seal Kit No. 300653.

MOTOR END VIEW

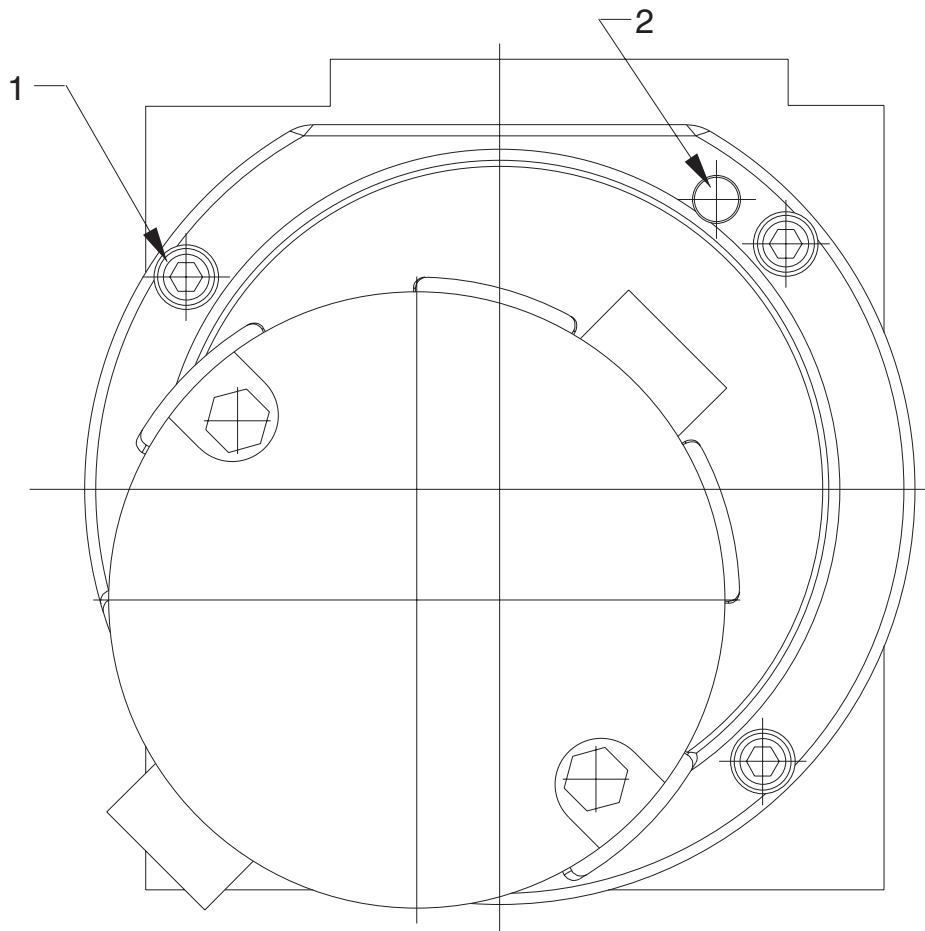

| Item No. | Part No. | No. Req'd | Description |
|----------|----------|-----------|---|
| 1 | 11434 | 3 | Screw (10-24 UNC X 1/2 Lg.; Torque to 60/80 in. lbs.) |
| 2 | 17567 | 2 | Pin |

HYDRAULIC SCHEMATIC

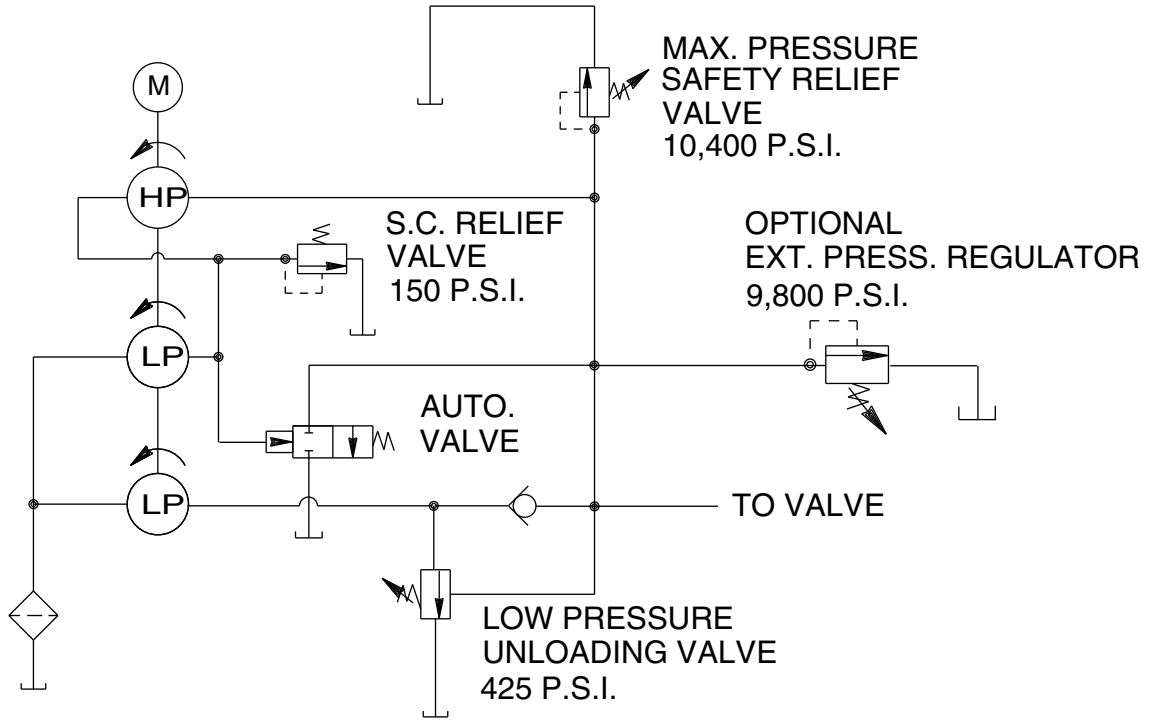

ELECTRICAL INFORMATION

Note: All electrical information and schematics for these units can be found in Form No. 102808 Operating Instructions.