

MODEL B AIR/HYDRAULIC PUMP TUBE STYLE

FOOT PEDAL STYLE
SHOWN

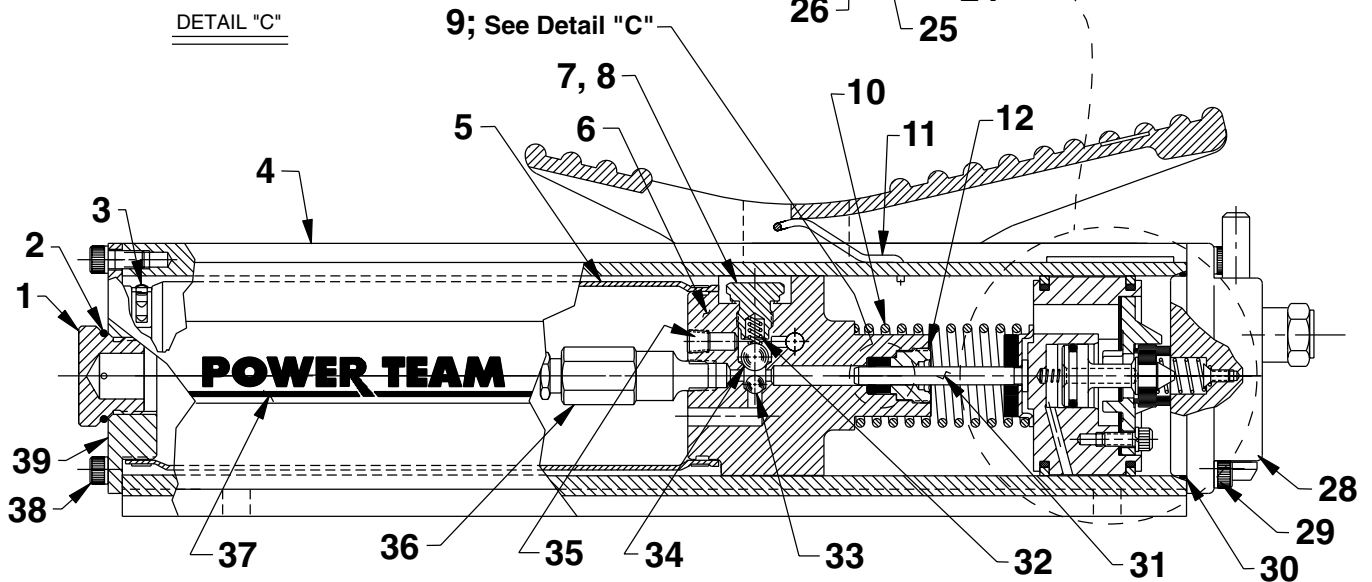

Note: Added Detail "C" at last revision(s) made to this form.

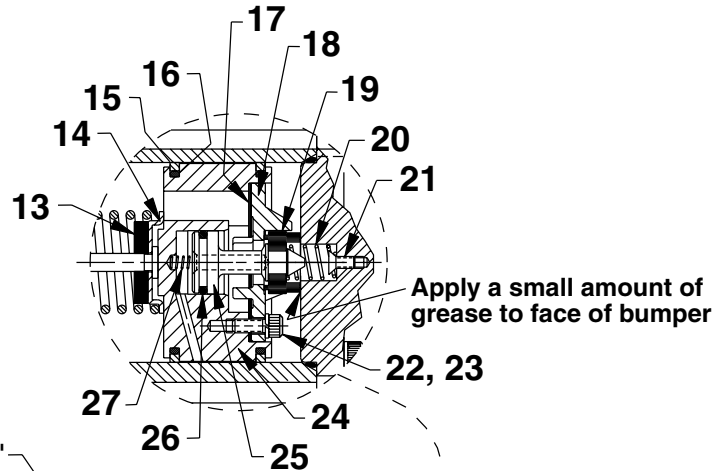
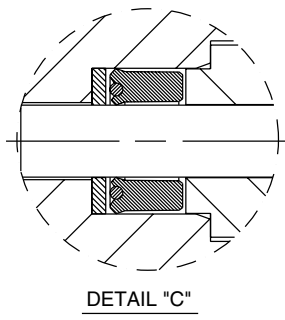
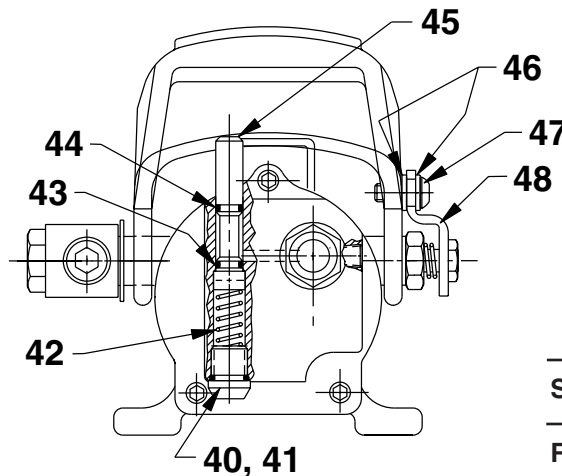

Parts List, Form No. 101786, Back sheet 1 of 3

Item No.	Part No.	No. Req'd	Description
1	252298	1	Filler Plug
2	*16684	1	O-ring (1.18 X 1.00)
3	*252303	2	Clamp
4	65471	1	Pump Housing (For PA9, PA9-35, PA9-PRO & PA9-CRN)
	65469	1	Pump Housing (For PA9H)
5	*421332	.50	Bladder (Cut to 8.280 / 8.220 Lg.)
6	65308	1	Pump Body
7	351394	1	Valve Screw (1/2-20 X 25/32 Lg.; Torque to 350/370 in. lbs.)
8	*14874	1	Copper Washer (.70 X .50)
9	*13934	1	U-cup & Backup
10	*13938	1	Spring (1.45 O.D. X 4.4)
11	351426	1	Spring Clip
12	*304295	1	Retainer (NOTE: See "INSTRUCTIONS FOR RETAINER REPLACEMENT" on sheet 3 of 3.)
13	*203143	1	Bumper
14	210994	1	Spring Guide
15	*14265	2	Piston Ring (2.77 X 2.54)
16	*251835	2	O-ring (2.31 X 2.12)
17	*28239	1	Gasket
18	33822	1	Piston End Plate Casting
19	*28183	1	Piston Poppet
20	*205679	1	Spring (.49 O.D. X .92)
21	205674	1	Flat Hd. Screw (8-32 X 3/8; Torque to 12/18 in. lbs.)
22	211054	3	Soc. Hd. Screw (10-24 X 1/2; Torque to 50/55 in. lbs.)
23	10241	3	Lockwasher (.33 X .20)
24	52390	1	Piston Body
25	305475	1	Exhaust Valve Stem
26	*211052	1	O-ring (.90 X .70)
27	*12692	1	Spring (.18 O.D. X 1.70)
28	58901	1	Rear Head
29	10008	3	Cap Screw (1/4-20 X 3/4 Lg.; Torque to 120/140 in. lbs.)
30	*252349	1	O-ring (2.75 X 2.65)
31	28226	1	Piston (1/4")
32	*10444	1	Spring (.25 O.D. X .41)
33	*10375	1	Steel Ball (1/4" Dia.; Seat at assembly)
34	*10378	1	Steel Ball (3/8" Dia.; Seat at assembly)
35	11084	1	Plug Fitting (1/16 NPTF)
36	21278	1	Relief Valve (Set at 10,100 to 10,700 PSI)
	21278-35	1	Relief Valve (Set at 3,500/3,800 PSI; For PA9-35)
	21278-40	1	Relief Valve (Set at 4,100/4,500 PSI; For PA9-CRN)
37	351341	2	Trade Name Decal
38	10807	3	Cap Screw (1/4-20 X 1/2 Lg.; Torque to 60/80 in. lbs.)
39	351409	1	End Filler Cap
40	250258	1	Screw (1/2-13 X 1/2 Lg.; Note: Apply Loctite 277 or equiv. Cure one hour before testing.)
41	15279	1	O-ring (.50 x .37 Nitrile)
42	*253479	1	Spring (.36 O.D. X 1.0)
43	*12522	1	O-ring (.37 X .25; Urethane; Note: Apply a small amount of grease at assembly.)
44	*12557	1	O-ring (.34 x .21; Note: Apply a small amount of grease at assembly.)
45	351423	1	Valve Stem
46	12719	2	Plain Washer (.63 X .29; For PA9, PA9-35, PA9-PRO & PA9-CRN)
47	15911	1	Button Hd. Screw (1/4-20 X 1/2; For PA9, PA9-35, PA9-PRO & PA9-CRN)
48	351371	1	Release Clip (Note: Adjust release clip so that hydraulic pressure starts to release when pedal is lifted off the top of the valve stem .150/.250 [For PA9, PA9-PRO & PA9-CRN] or .100/.300 [For PA9-35].)

Part numbers marked with an asterisk (*) are contained in Repair Kit No. 300949.

Note: Shaded areas reflect last revision(s) made to this form.

TOP VIEW

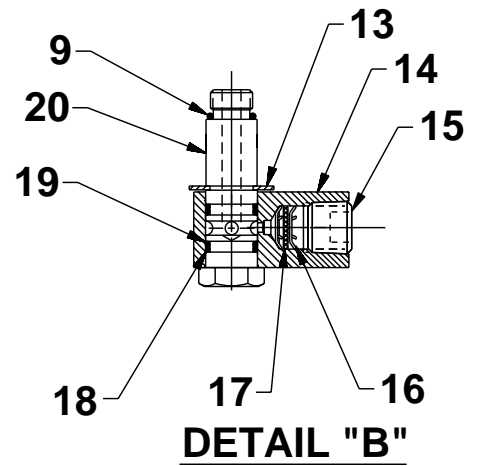
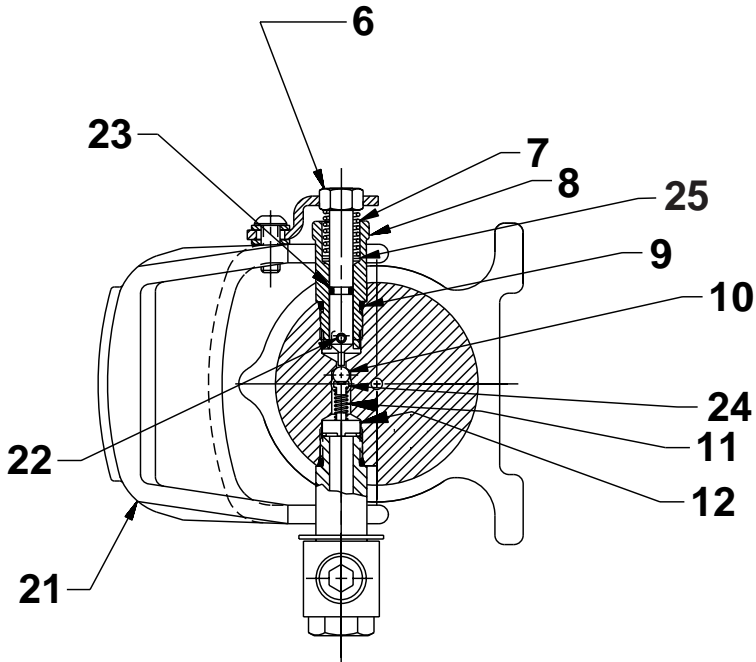
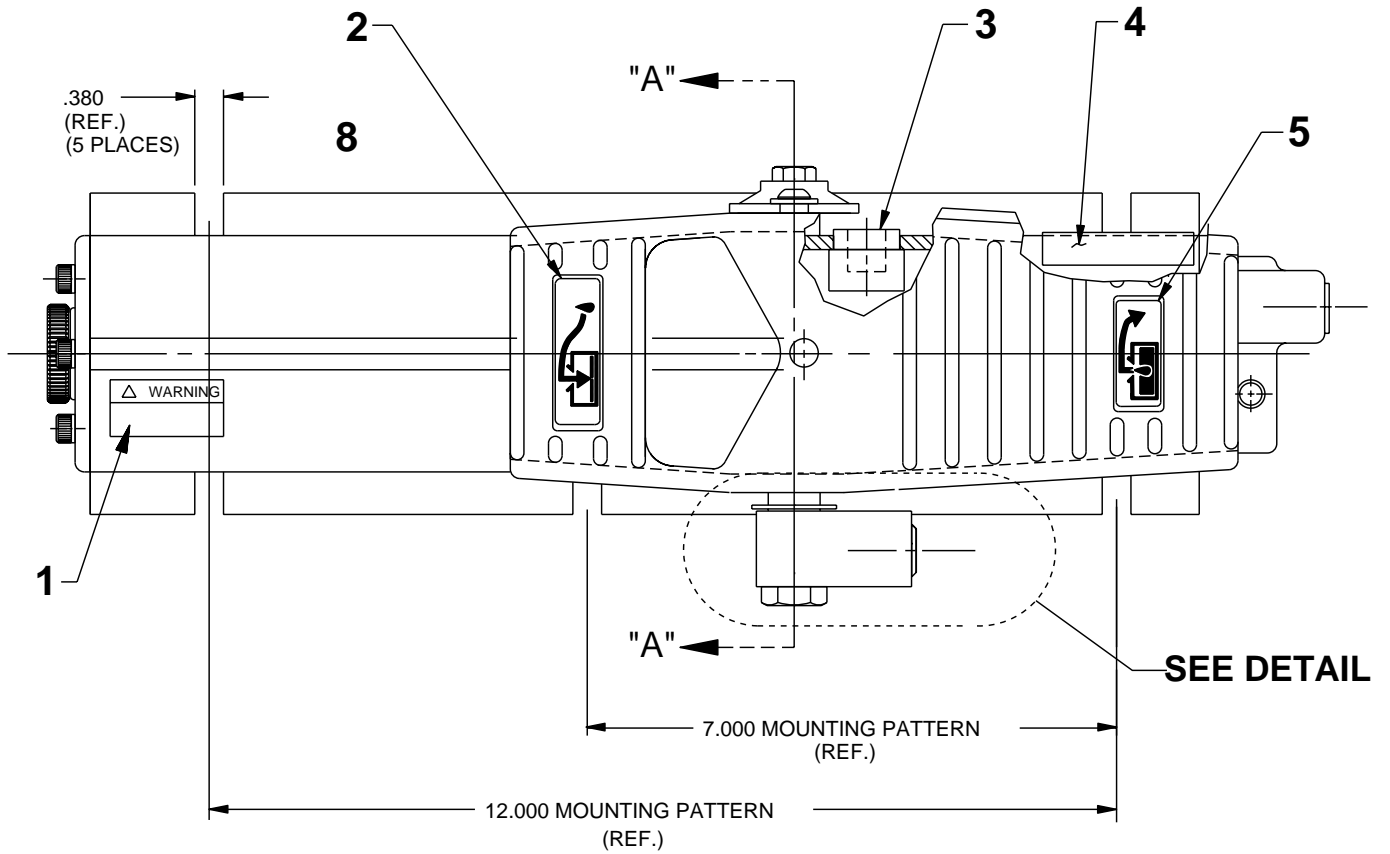

Item No.	Part No.	No. Req'd	Description
1	222142	1	Warning Decal
2	251758	1	Instruction Decal (Release)
3	*252300	2	Muffler
4	14350	1	Warning Decal
5	251757	1	Instruction Decal (Pump)
6	252526	1	Release Pin (Release stem must move freely through clip when assembled.)
7	*253223	1	Spring (.49 O.D. X 1.0)
8	351413	1	Pivot Cam (Torque to 280/300 in. lbs.)
9	*10300	2	O-ring (.62 X .46)
10	*10374	1	Steel Ball (7/32" Dia.; Seat at assembly)
11	*14282	1	Spring (.25 O.D. X .68)
12	252445	1	Bushing
13	11902	1	External Retaining Ring
14	351385	1	Swivel Block
15	16232	1	Plug Fitting (3/8 NPTF)
16	*11088	2	Internal Retaining Ring (.31 X .010)
17	*250638	1	Oil Filter Disc
18	*12391	2	Backup Washer
19	*11284	2	O-ring (.68 x .56 Nitrile)
20	351693	1	Swivel Fitting (Torque to 580-600 in. lbs.)
21	421471	1	Machine Foot Pedal
22	10796	1	Dowel Pin (.13 X .50)
23	*10265	1	O-ring (.31 X .18)
24	252856	1	Guide, Ball
25	253663	2	Washer

PARTS INCLUDED BUT NOT SHOWN

253293	1	Decal, Raise & Lower (For PA9H only)
--------	---	--------------------------------------

Part numbers marked with an asterisk (*) are contained in Repair Kit No. 300949.

KNOB COMPONENTS FOR PA9H ONLY

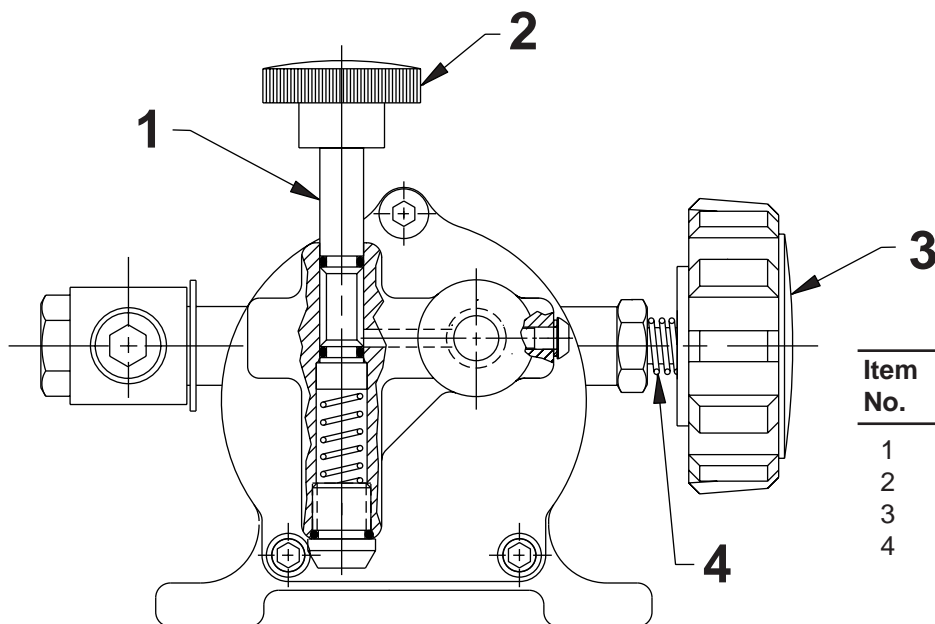

Item No.	Part No.	No. Req'd	Description
1	351345	1	Valve Stem
2	351346	1	Knob
3	351368	1	Knob
4	252535	1	Release Pin

INSTRUCTIONS FOR RETAINER REPLACEMENT

Your pump's retainer is locked into place by one of the two following methods. Determine which method was used on your pump's retainer, then follow the appropriate steps to remove the old and install and stake the new.

Method 1 - Retainer shows no sign of stake marks

1. This retainer has been locked in place with a Loctite product. To replace it, a moderate amount of heat needs to be applied to the cylinder nut (in the area of the retainer) to soften the existing Loctite allowing it to be removed.
2. Install the new retainer into the cylinder nut and torque to 80/100 in. lbs. **Note: Do not use a Loctite product this time but stake the new retainer in place according to instructions in Step 3.**
3. To lock retainer into place, use a center punch positioned in the seam between the retainer and the cylinder nut and stake the new retainer in two places approximately 180° apart.

Method 2 - Retainer has two stake marks in the seam between the retainer and the cylinder nut

1. For replacement of this retainer, the stake marks must be removed. Using a 1/8" or larger diameter drill bit, remove the existing stakes by drilling a short distance into the stake marks. Remove the retainer.
2. Install the new retainer into the cylinder nut and torque to 80/100 in. lbs.
3. To lock retainer into place, use a center punch positioned in the seam between the retainer and the cylinder nut and stake the new retainer in two places approximately 180° apart.

NOTE: Do not stake in the old stake marks.