

**MODEL B**  
**DOUBLE-ACTING, HOLLOW CENTER**  
**HYDRAULIC CYLINDER**  
Max. Capacity: 149.7 Tons at 10,000 PSI

To Parts List

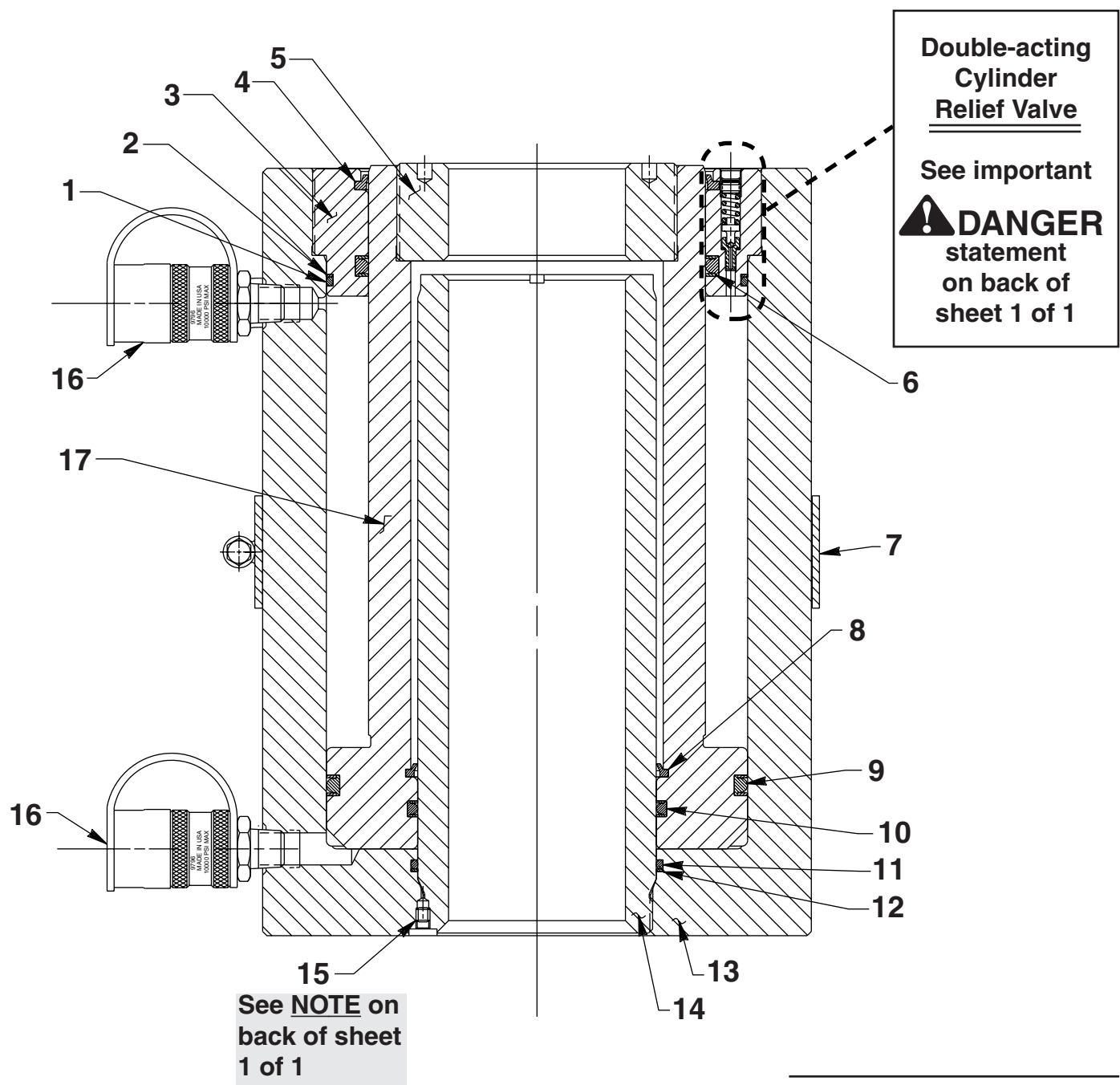

Double-acting  
Cylinder  
Relief Valve

See important  
**! DANGER**  
statement  
on back of  
sheet 1 of 1

See NOTE on  
back of sheet  
1 of 1

Note: Shaded areas reflect last revision(s) made to this form.

**⚠ DANGER:** To help avoid possible serious personal injury or death,

- In the event that the cylinder retract port is ever restricted or plugged, a double-acting cylinder relief valve will help prevent excessive pressure from building in the cylinder. **DO NOT** attempt to adjust or service this relief valve! If oil leakage is detected from this relief valve, discontinue use of the cylinder immediately and contact Power Team Technical Services. Only Power Team Authorized Hydraulic Service Centers should service this relief valve.

Item No.	Part No.	No. Req'd	Description
1	*250197	1	O-ring (7.50 x 7.25 NITRILE)
2	*250198	1	Washer, Backup (7.50 x 7.25)
3	58047	1	Nut, Retainer (8-12; NOTE: Torque to 590 Ft. Lbs.)
4	*250203	1	Wiper, Rod (6.50 x 6.00 URE)
5	350066	1	Insert, Threaded
6	*250200	1	T-seal (6.50 x 6.00 x .36 L)
7	59225OR9	1	Handle, Cylinder Lift
8	*250202	1	Wiper, Rod (4.69 x 4.25 URE)
9	*250201	1	T-seal (7.50 x 7.00 x .36 L)
10	*250199	1	T-seal (4.63 x 4.25 x .27 L)
11	*10858	1	O-ring (4.50 x 4.25 NITRILE)
12	*19171	1	Washer, Backup (4.50 x 4.25)
13	65992	1	Body, Cylinder
14	420040	1	Pipe, Stand
15	10556	1	Screw, Set (1/4-20 x 1/4; See NOTE below )
16	9796	2	Coupler, Quick Cylinder Half
17	64054	1	Rod, Piston

**PARTS INCLUDED BUT NOT SHOWN**

*37782	1	Decal, Warning
351882	1	Decal, Tradename (Power Team)



Part numbers marked with an asterisk (\*) are contained in Repair Kit No. 300583.

**NOTE:** Cylinders built after 1-1-99 do not use this set screw to lock the standpipe and cylinder body together. Loctite 242 is used on last 2-3 standpipe threads only!

Note: Shaded areas reflect last revision(s) made to this form.

Refer to any operating instructions included with this product for detailed information about operation, testing, disassembly, reassembly, and preventive maintenance.

Items found in this parts list have been carefully tested and selected. **Therefore: Use only genuine Power Team replacement parts!**

Additional questions can be directed to our Technical Services Department.