

HYDRAULIC TOE JACK (Model A)

Model J58T Max. Capacity: 5 Ton
Model J109T Max. Capacity: 10 Ton

Read and carefully follow the warnings and operating instructions before using this jack. Most problems with new equipment are caused by improper operation or setup.

NOTE: Inspect the pump upon arrival. The carrier, not the manufacturer, is responsible for any damage resulting from shipment.

SAFETY PRECAUTIONS



WARNING: To help prevent personal injury or damage to equipment,

- Do not exceed the maximum load capacity of the jack.
- Do not add additional load to a lifted load.
- Do not use in unstable or hazardous positions.
- Unit must be used on flat surfaces able to carry the load.
- Keep clear of lifted loads.
- The load must be stable during lifting. An unstable load may cause the jack or load to slip.
- Do not use the jack(s) if damaged, altered, or in poor condition.
- Do not lift people or loads with people on them.
- This hydraulic jack is for professional use only and should be used only by persons trained in its use.
- Do not lift at the end of the toe. Fully engage the load with the toe.
- Use only recommended hydraulic fluid in this unit.
- Do NOT, under any circumstances, tamper with the adjustment of the jack's internal relief valve screw. To do so may cause the jack to fail.
- When lifting by the toe, wedge the head of the jack on the load to avoid bending the column. Refer to illustration at left.
- Read operating instructions and A.N.S.I. B30.1 safety code for jacks.
- The owner of the jack must ensure that all safety-related decals are maintained and replaced as they become hard to read.
- This guide cannot cover every situation, so always do the job with safety first.

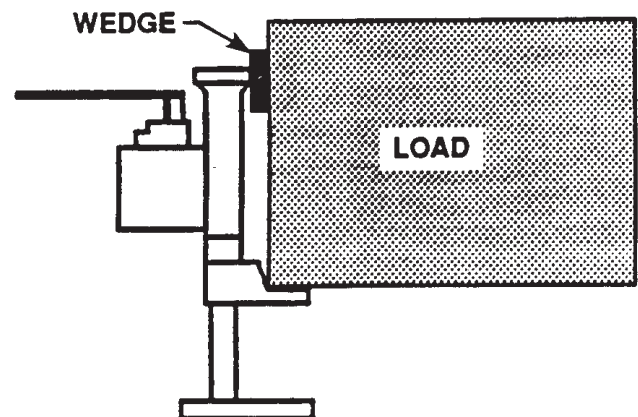

OPERATION OF THE JACK

IMPORTANT: Do not carry the jack by the jacking lever.

Lifting a Load

1. Position the load on the toe of the jack.



WARNING: Do not lift at the end of the toe. Fully engage the load with the toe.

IMPORTANT: When lifting by the toe, wedge the head of the jack on the load to avoid bending the column.

2. Turn the release valve knob in a clockwise direction until it will turn no more.
3. Pump the jacking lever in an up and down motion.

Lowering a Load

1. Slowly loosen the release valve knob by turning it in a counterclockwise direction. The more the knob is loosened, the faster the load will be lowered. To stop the jack instantly from lowering a load, tighten the release valve knob by turning it in a clockwise direction.

DISASSEMBLY OF THE JACK

NOTE: Refer to parts list on back page 2 of 3 and page 3 of 3.

Draining the Jack

1. Extend the jack to full stroke. Wedge the toe of the jack on the base to hold in this position.
2. Remove the cylinder plug (6) and drain oil.

Disassembly of the Pump

1. Remove the hinge pin (7).
2. Pull out the lever assembly (2), piston (23), and connecting link (5).
3. Remove the four screws (27) that hold the pump to the reservoir. Separate the pump from the reservoir.
4. Remove the bladder (20) and drain the oil from it. Using a clean, absorbent cloth, wipe any remaining oil out of the bladder.

Disassembly of the Cylinder

1. Remove the spring clip (15) with a locking pliers.
2. Pull out the cylinder rod/base plate assembly (9) and the toe (17) from the jack body.
3. Heat the cylinder guide (8) slightly to soften the locking compound on the threads. Disassemble it from the cylinder rod.
4. Remove the o-ring (14) and U-cup (16) from the toe.

Disassembly of the Pump

1. Unthread the inlet check valve body (21).
2. Remove the inlet check found at the bottom of the body by unscrewing the perforated screw (12). Remove the ball (13) and the spring (18).
3. Remove the breather valve screws (2) found at the top of the pump barrel (28) and remove the ball (4) and spring (3).
4. Unthread the outlet check screw (12) found between the o-rings (24) and, remove the spring (11) and ball (13).
5. Drive out the spring pin (4) and remove the release valve knob (3).
6. Remove the retaining ring (2) before removing the release valve.
7. Using a small press or a mallet and a piece of soft metal tubing, push the piston cartridge (29) out of the pump body.
8. Remove o-ring (26), wiper (25), and U-cup (30).

Disassembly of the Release Valve

1. Unscrew the seat (9) which will give you access to then remove the ball (8), ball follower (7) and spring (6).

Lever Disassembly

1. Remove the pins (4) that will make it possible to separate the lever (2), piston (23) and link (5).

NOTE: Clean all jack parts (except o-rings, wipers, and bladder) with a degreasing agent and dry completely.

ASSEMBLY OF THE JACK

Assembly of the Cylinder

1. Replace o-ring (14) and U-cup (16) on the toe (17).
2. Grease the bore of the toe (17) with a non-silicone lubricant.
3. Mount the toe (17) on the cylinder rod (9).
4. Tighten the guide (8) on the cylinder rod using a thread locking compound. Clean away any excess compound.
5. Grease the exterior machined portion of the toe (17) with a non-silicone lubricant.
6. Assemble the cylinder rod/base plate assembly (9), the toe (17), and the guide (8) into the body of the jack.
7. Drive the spring stock (15), round end first, into the hole at the base of the jack body using a pliers to guide the spring.

Assembly of the Pump

1. Install o-ring (26), U-cup (25), and wiper (30) on the piston cartridge (29). Grease the pump barrel with a suitable lubricant.
2. Seat the piston cartridge into its housing in the pump barrel (28) using a small press or mallet and a piece of soft metal.
3. Replace the inlet check valve into the pump body (21) by installing the ball (13), spring (18) and perforated screw (12).

NOTE:

- **The inlet check valve may be reconditioned by coining the ball into its seat with a hammer and soft punch.**
 - **Springs (11 & 18) look very much alike and must not be confused. Spring (18) is a lighter rate than spring (11).**
4. Replace o-ring (22) on the inlet check valve body. Thread the valve body onto the pump barrel (29).
 5. Reassemble the outlet check valve into the pump barrel (28) by installing the ball (13), spring (11) and screw (12) respectively.
 6. Reinstall the breather valve into the top of the pump barrel (28) by first installing the spring (3), then the ball (4) and last the screw (2).
 7. Coat the inside of the jack body with a suitable lubricant to accept the pump body.

Assembly of the Release Valve

1. Reassemble the spring (6), ball follower (7), ball (8), and seat (9).
2. Grease and replace o-ring (1).
3. Install the release valve in the pump body.
4. Install the retaining ring (2).

Assembly of the Lever

1. Using two pins (4), attach the connecting link (5) and the piston (23) to the lever (2). **IMPORTANT: Do NOT damage the piston.**

Final Assembly of the Jack

1. Place the bladder (20) in the reservoir of the jack body.
2. Mount the pump into its housing on the jack body. Tap the pump into place with a mallet, while protecting the top of the pump with a piece of wood. Secure with four screws (27).
3. Position the jack vertically and hold it in the extended position by wedging the toe on the base.
4. Open the release valve.
5. Using a funnel with a filter, fill the jack with Power Team hydraulic fluid through the cylinder cap hole while holding the breather valve ball off its seat with a pin or punch. Fill until fluid comes out of the breather valve. Allow the breather valve ball to reseal.
6. Close the release valve and continue to fill the jack with oil until oil comes out of the top of the cylinder.
7. Replace the cylinder plug (6) and the o-ring (7).
8. Fill the piston cavity with oil.
9. Install the lever assembly (2) with pin (7), nut (8) and washer (6).
10. Turn the jack upside down for a few seconds.
11. Push the breather valve ball off of its seat until oil stops coming out of the screw.
12. Install protective screw (1).

SIDE VIEW

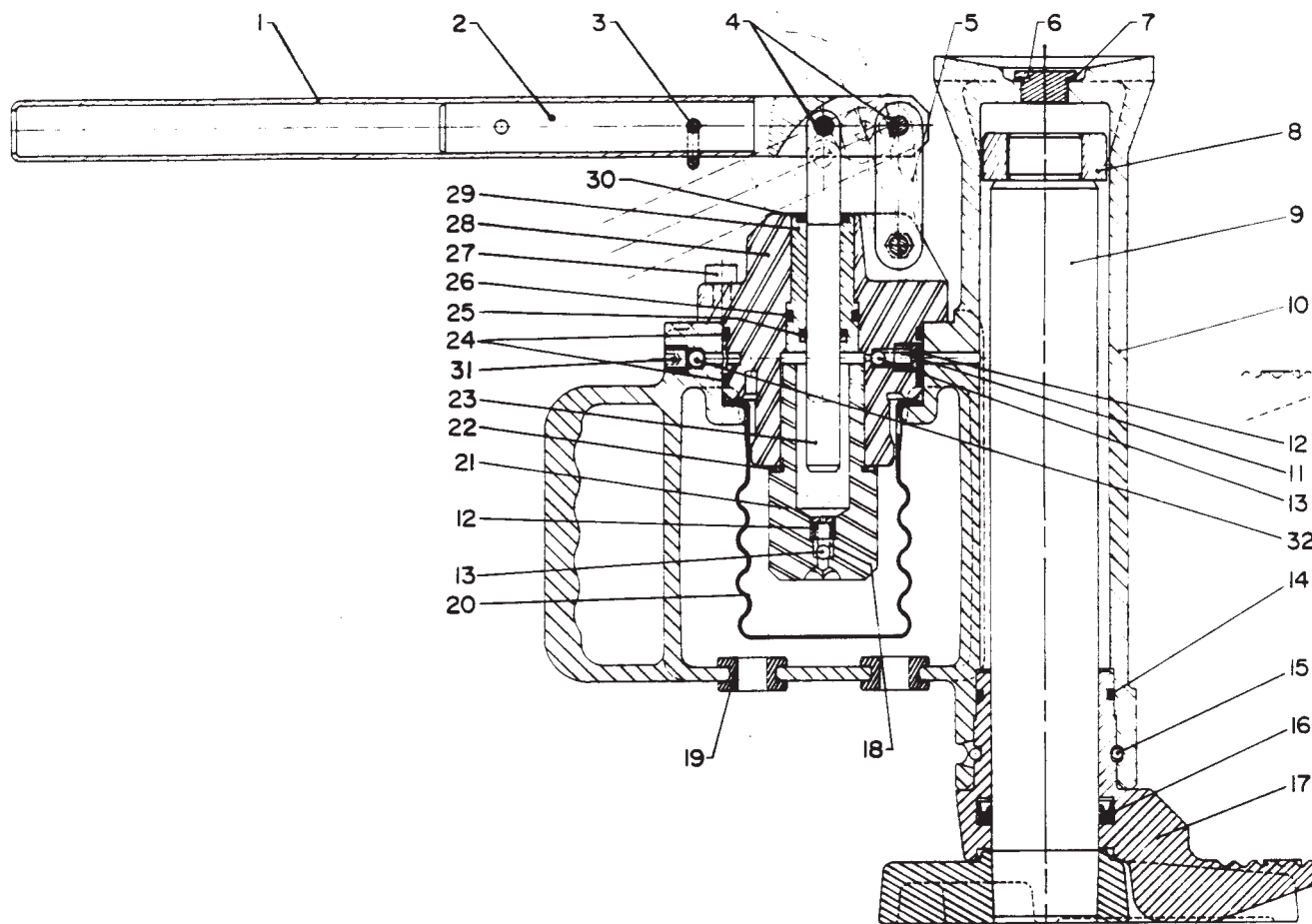

Item No.	Part No.	No. Req'd	Description
1	250072	1	Tube
2	250071	1	Lever
3	250073	1	Straight Pin
4	250075	2	Pin
5	250074	1	Link
6	250065	1	Plug
7	250066	1	O-ring
8	250061	1	Guide (For J58T)
	250106	1	Guide (For J109T)
9	250059	1	Cylinder and Base Plate (For J58T)
	250104	1	Cylinder and Base Plate (For J109T)
10	250058	1	Body (For J58T)
	250103	1	Body (For J109T)
11	+250089	1	Spring
12	+250090	2	Perforated Screw
13	+250087	2	Ball
14	*250063	1	O-ring (For J58T)
	**250108	1	O-ring (For J109T)
15	*250060	1	Retaining Ring (For J58T)
	**250105	1	Retaining Ring (For J109T)
16	*250064	1	U-cup (For J58T)
	**250109	1	U-cup (For J109T)

Item No.	Part No.	No. Req'd	Description
17	250062	1	Toe (For J58T)
	250107	1	Toe (For J109T)
18	+250088	1	Spring
19	250068	2	Perforated Rubber Plug
20	▲250067	1	Bladder
21	250081	1	Valve Body
22	250082	1	O-ring
23	250083	1	Piston
24	▲250086	2	O-ring
25	250085	1	U-cup
26	250084	1	O-ring
27	250070	4	Screw
28	250079	1	Pump Barrel
29	250080	1	Piston Cartridge
30	250217	1	Wiper
31	+250091	1	Screw
32	+250087	1	Ball

PARTS INCLUDED BUT NOT SHOWN

250110	1	Warning Decal
250111	1	Trade Name Decal (For J58T)
250112	1	Trade Name Decal (For J109T)

Part numbers marked with an asterisk (*) are contained in Column Assembly Repair Kit No. 250113 (for J58T).
 Part numbers marked with two asterisks (**) are contained in Column Assembly Repair Kit No. 250114 (for J109T).
 Part numbers marked with a dagger (†) are contained in Valve Assembly Repair Kit No. 250117.
 O-ring Set Repair Kit No. 250116. (Discontinued)
 Part numbers marked with a triangle (▲) are contained in Bladder Change Repair Kit No. 250115.

Note: Shaded areas reflect last revision(s) made to this form.

TOP VIEW

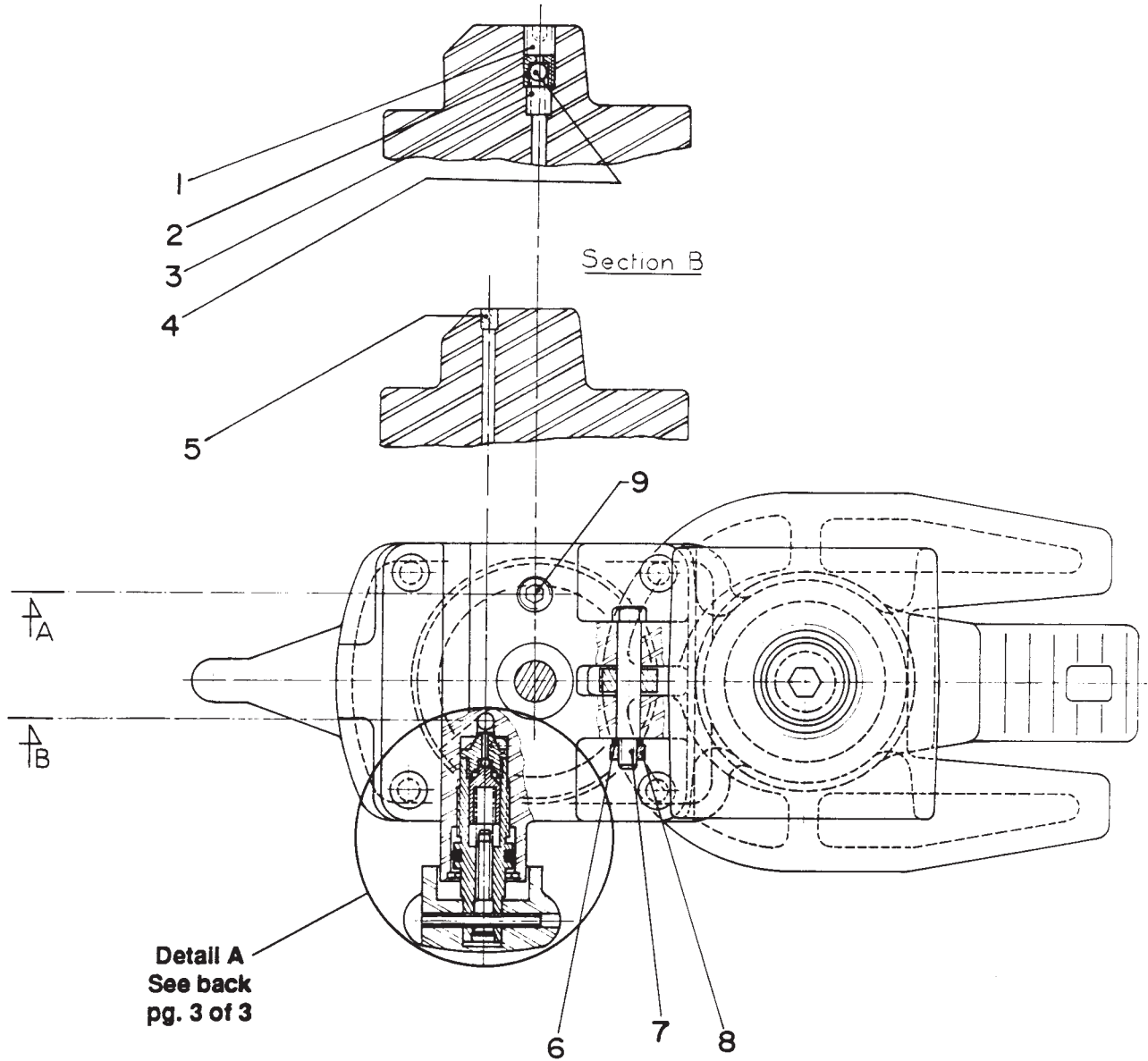

Item No.	Part No.	No. Req'd	Description
1	†250091	1	Screw
2	†250090	1	Perforated Screw
3	250088	1	Spring
4	†250087	1	Ball
5	250069	1	Cap
6	250078	1	Washer
7	250076	1	Hinge Pin
8	250077	1	Nut
9	250069	1	Cap

Part numbers marked with a dagger (†) are contained in Valve Assembly Repair Kit No. 250117.

DETAIL A

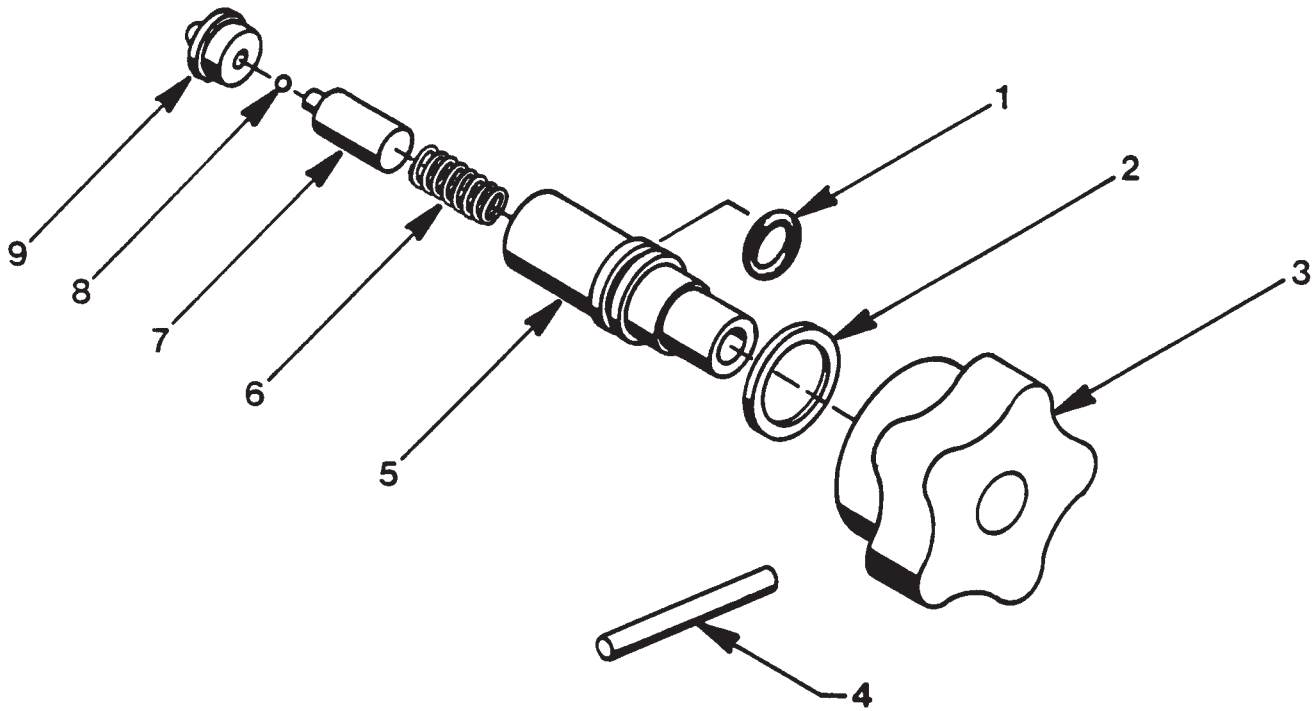

Item No.	Part No.	No. Req'd	Description
1	250098	1	O-ring
2	250099	1	Ring
3	250100	1	Handle
4	250101	1	Pin
5	250092	1	Release Valve
6	250096	1	Spring
7	250095	1	Ball Follower
8	250094	1	Ball
9	250093	1	Seat