

MODEL B AIR/HYDRAULIC PUMP TUBE STYLE

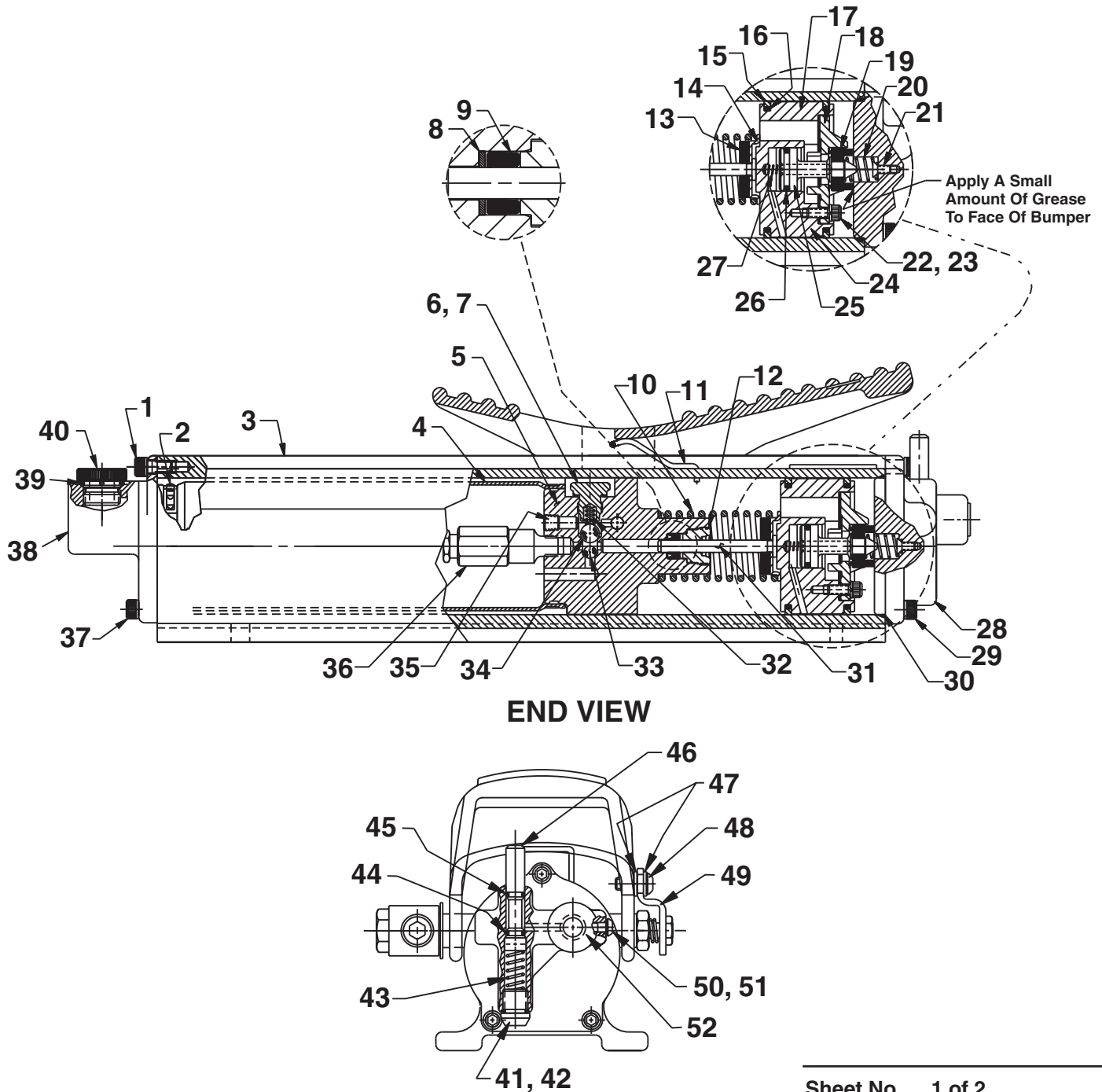

END VIEW

Parts List, Form No. 108141, Back sheet 1 of 2

Item No.	Part No.	No. Req'd	Description
1	10807	1	Soc. Hd. Screw (1/4-20 x 1/2; Torque to 60/80 in. lbs.)
2	*252303	2	Clamp
3	65471	1	Pump Housing
4	*421332	.50	Bladder (Cut to 8.280 / 8.220 Lg.)
5	66444	1	Pump Body
6	351394	1	Valve Screw (1/2-20 X 25/32 Lg.; Torque to 350/370 in. lbs.)
7	*14874	1	Copper Washer (.70 X .50)
8	251005	1	Backup Washer (.50 x .25)
9	*260020	1	U-cup (.468 x .218 x .250 H)
10	*13938	1	Spring (1.45 O.D. X 4.4)
11	351426	1	Spring Clip
12	*360057	1	Retainer (NOTE: See "INSTRUCTIONS FOR RETAINER REPLACEMENT" on back sheet 2 of 2.)
13	*203143	1	Bumper (Adhere to spring guide [Item #14] with 3M 77 spray adhesive.)
14	210994	1	Spring Guide
15	*14265	2	Piston Ring (2.77 X 2.54)
16	*251835	2	O-ring (2.31 X 2.12)
17	*28239	1	Gasket
18	33822	1	Piston End Plate Casting
19	*28183	1	Piston Poppet
20	*205679	1	Spring (.49 O.D. X .92)
21	205674	1	Flat Hd. Screw (8-32 X 3/8; Torque to 12/18 in. lbs.)
22	211054	3	Soc. Hd. Screw (10-24 X 1/2; Torque to 50/55 in. lbs.)
23	10241	3	Lockwasher (.33 X .20)
24	52390	1	Piston Body
25	305475	1	Exhaust Valve Stem
26	*211052	1	O-ring (.90 X .70)
27	*12692	1	Spring (.18 O.D. X 1.70)
28	58901	1	Rear Head
29	10008	3	Cap Screw (1/4-20 X 3/4 Lg.; Torque to 120/140 in. lbs.)
30	*252349	1	O-ring (2.75 X 2.65)
31	260030	1	Piston (7/32")
32	*10444	1	Spring (.25 O.D. X .41)
33	*10375	1	Steel Ball (1/4" Dia.; Seat at assembly)
34	*10378	1	Steel Ball (3/8" Dia.; Seat at assembly)
35	11084	1	Plug Fitting (1/16 NPTF)
36	207975-103	1	Relief Valve (Set at 9,900/10,300 PSI)
38	421460	1	End Filler Cap
39	*10274	1	O-ring (.87 x .68 Nitrile)
40	351245	1	Filler Cap
41	250258	1	Screw (1/2-13 X 1/2 Lg.; Note: Apply Loctite 277 or equiv. Cure one hour before testing.)
42	15279	1	O-ring (.50 x .37 Nitrile)
43	*253479	1	Spring (.36 O.D. X 1.0)
44	*12522	1	O-ring (.37 X .25; Urethane; Note: Apply a small amount of grease at assembly.)
45	*10266	1	O-ring (.37 X .25; Note: Apply a small amount of grease at assembly.)
46	351423	1	Valve Stem
47	12719	2	Plain Washer (.63 X .29)
48	15911	1	Button Hd. Screw (1/4-20 X 1/2)
49	351371	1	Release Clip (Note: Adjust release clip so that hydraulic pressure starts to release when pedal is lifted off the top of the valve stem .100/.300.)
50	251486	1	Screw, Button Hd (10-24 x 1/2; Torque to 45/55 in. lbs.)
51	14319	1	Special Washer (.31 x .19)
52	14794	1	Plastic Cap

Part numbers marked with an asterisk (*) are contained in Repair Kit No. 300949.

TOP VIEW

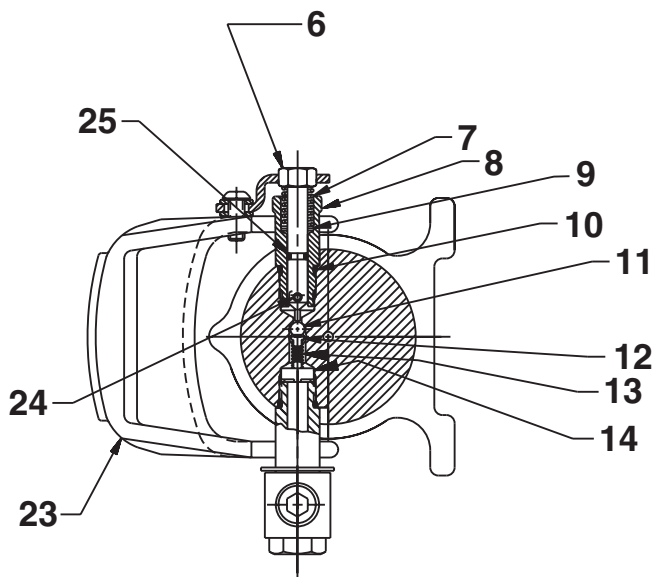
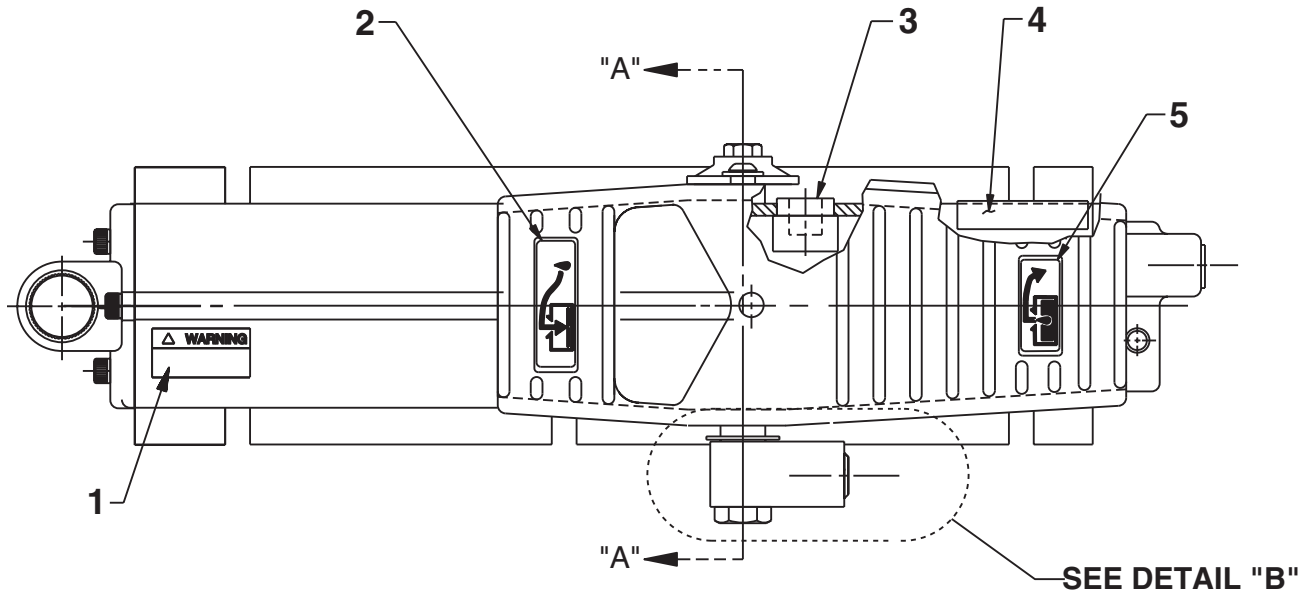

SECTION A-A

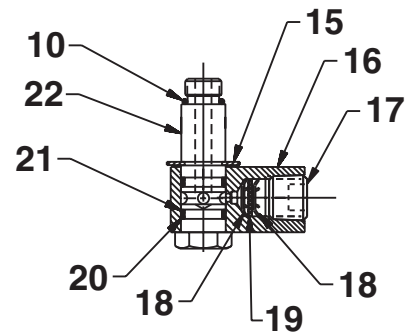

DETAIL "B"

Parts List, Form No. 108141, Back sheet 2 of 2

Item No.	Part No.	No. Req'd	Description	Item No.	Part No.	No. Req'd	Description
1	222142	1	Warning Decal	13	*14282	1	Spring (.25 O.D. X .68)
2	251758	1	Instruction Decal (Release)	14	252445	1	Bushing
3	*252300	2	Muffler	15	11902	1	External Retaining Ring
4	14350	1	Warning Decal	16	351385	1	Swivel Block
5	251757	1	Instruction Decal (Pump)	17	16232	1	Plug Fitting (3/8 NPTF)
6	252526	1	Release Pin (Release stem must move freely through clip when assembled.)	18	*11088	2	Internal Retaining Ring (.31 X .010)
7	*253223	1	Spring (.49 O.D. X 1.0)	19	*250638	1	Oil Filter Disc
8	351413	1	Pivot Cam (Torque to 280/300 in. lbs.)	20	*12391	2	Backup Washer
9	253663	2	Washer	21	*11284	2	O-ring (.68 x .56 Nitrile)
10	*10300	2	O-ring (.62 X .46)	22	351693	1	Swivel Fitting (Torque to 580-600 in. lbs.)
11	*10374	1	Steel Ball (7/32" Dia.; Seat at assembly)	23	421471	1	Machine Foot Pedal
12	252856	1	Ball Guide	24	10796	1	Dowel Pin (.13 X .50)
				25	*10265	1	O-ring (.31 X .18)

Part numbers marked with an asterisk (*) are contained in Repair Kit No. 300949.

INSTRUCTIONS FOR RETAINER REPLACEMENT

Your pump's retainer is locked into place by one of the two following methods. Determine which method was used on your pump's retainer, then follow the appropriate steps to remove the old and install and stake the new.

Method 1 - Retainer shows no sign of stake marks

1. This retainer has been locked in place with a Loctite product. To replace it, a moderate amount of heat needs to be applied to the cylinder nut (in the area of the retainer) to soften the existing Loctite allowing it to be removed.
2. Install the new retainer into the cylinder nut and torque to 80/100 in. lbs. **Note: Do not use a Loctite product this time but stake the new retainer in place according to instructions in Step 3.**
3. To lock retainer into place, use a center punch positioned in the seam between the retainer and the cylinder nut and stake the new retainer in two places approximately 180° apart.

Method 2 - Retainer has two stake marks in the seam between the retainer and the cylinder nut

1. For replacement of this retainer, the stake marks must be removed. Using a 1/8" or larger diameter drill bit, remove the existing stakes by drilling a short distance into the stake marks. Remove the retainer.
2. Install the new retainer into the cylinder nut and torque to 80/100 in. lbs.
3. To lock retainer into place, use a center punch positioned in the seam between the retainer and the cylinder nut and stake the new retainer in two places approximately 180° apart.

NOTE: Do not stake in the old stake marks.