

MODEL B
AIR DRIVEN WITH REMOTE CONTROL
HYDRAULIC PUMP
Max. Capacity: 10,000 PSI

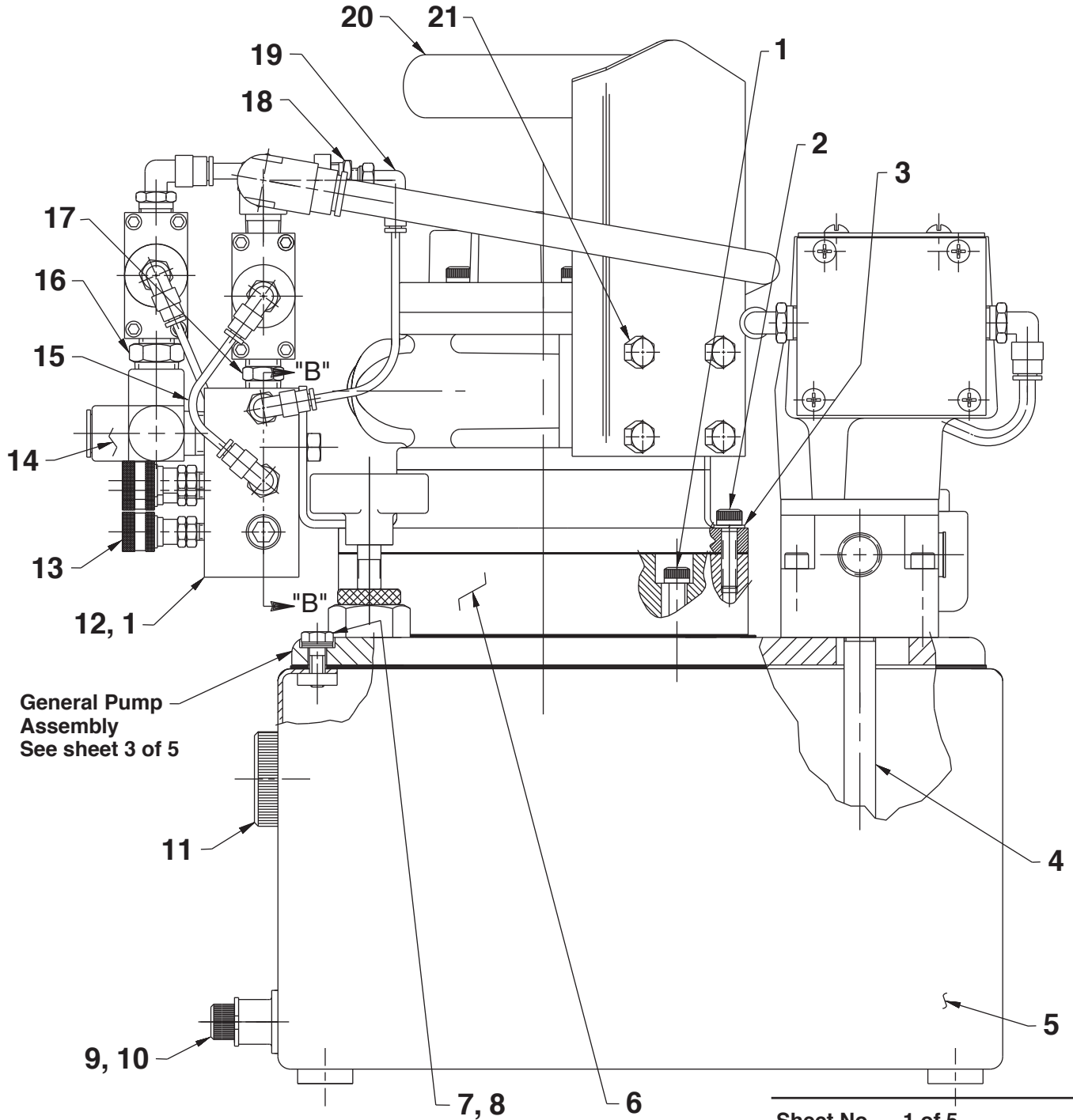

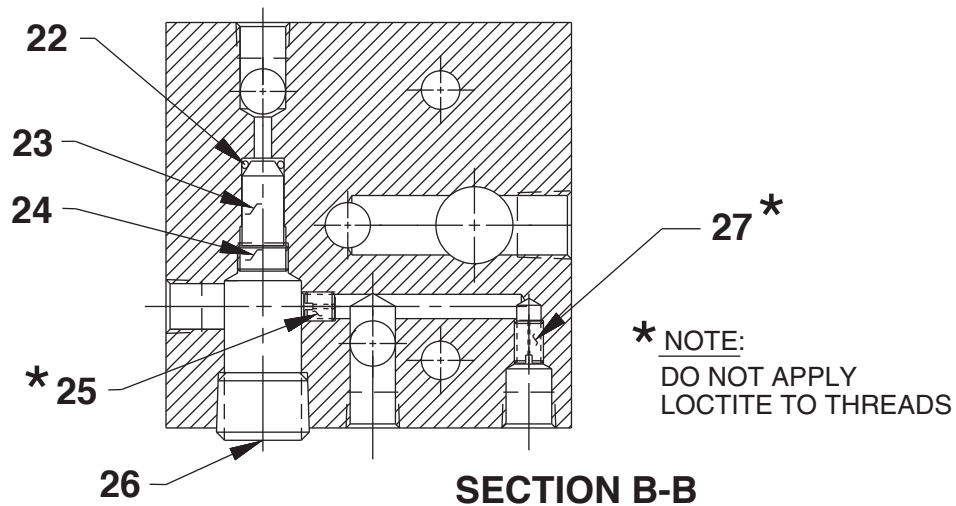

Item No.	Part No.	No. Req'd	Description	Item No.	Part No.	No. Req'd	Description
1	10022	6	Soc. Hd. Screw (1/4-20 x 1-1/2)	15	14281	.8'	Nylon Tubing
2	10016	3	Soc. Hd. Screw (1/4-20 x 1)	16	12328	1	Straight Fitting (1/4 NPTF)
3	10244	3	Lockwasher (.49 x .26)	17	16494	1	Straight Fitting (1/4 NPTF)
4	200609	1	Drain Tube	18	206324	1	Straight Fitting (1/4 NPTF)
5	420327	1	Reservoir	19	250804	2	90° Elbow Fitting
6	422056	1	Motor Base	20	422102BK2	1	Handle Weldment
7	12825	1	Cap Screw (1/4-20 x 5/8)	21	10005	4	Cap Screw (1/4-20 x 1/2)
8	10442	3	Copper Washer (.37 x .25)	22	10265	1	O-ring (.31 x .18 Nitrile)
9	10412	1	Soc. Hd. Screw (3/8-16 x 1/2)	23	253531	1	Check Valve (3000 PSI)
10	19779	1	Seal Washer (.73 x .42)	24	17240	1	Hollow Lock Screw (3/8-24 x 3/16)
11	17586	1	Sight Gauge (1-1/2")	25	252173	1	Orifice Screw (12-24 x 1/4)
12	501118	1	Manifold	26	10909	1	Plug Fitting (3/8 NPTF)
13	213344	3	Female Quick Coupler	27	214990	1	Restrictor Screw (12-24 x 5/16)
14	10623	1	Tee Fitting (3/8 NPTF)				

HYDRAULIC SCHEMATIC

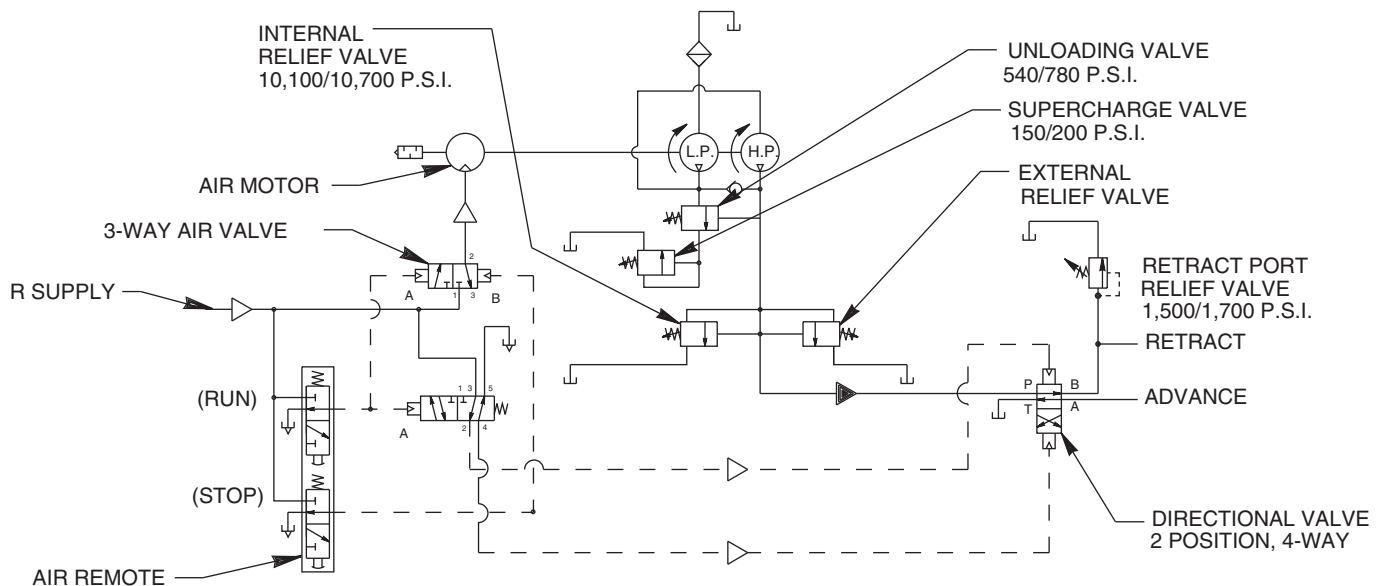

TOP VIEW

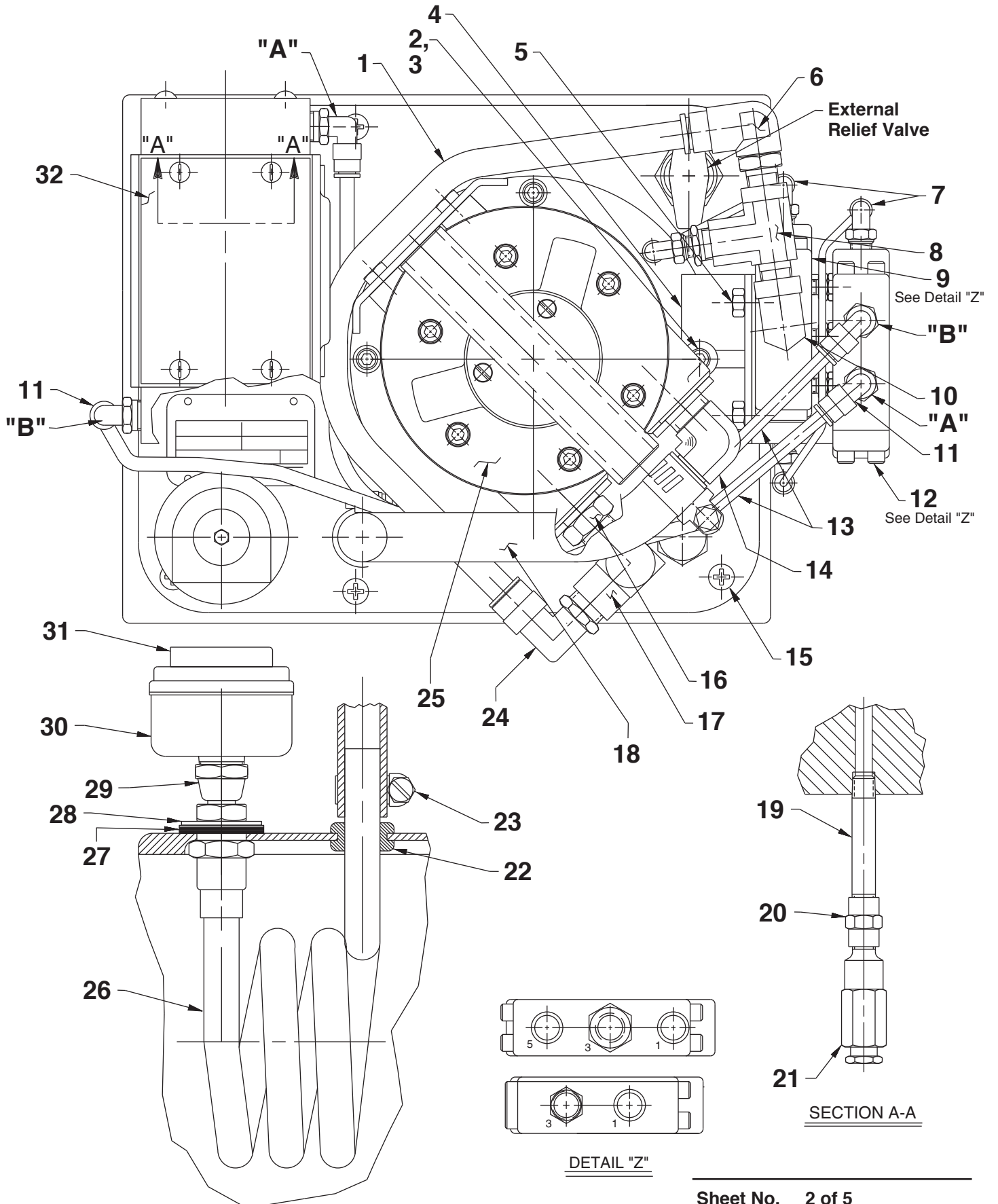

Parts List, Form No. 108179, Back sheet 2 of 5

Item No.	Part No.	No. Req'd	Description	Item No.	Part No.	No. Req'd	Description
1	252296	1.67'	Nylon Tubing	20	18841	1	Straight Fitting
2	12719	1	Plain Washer (.63 x .29)	21	21278-15	1	Relief Valve Assembly (Set at 1,500/1,700 PSI)
3	10020	1	Soc. Hd. Screw (1/4-20 x 1-1/4)	22	212896	1	Grommet
4	360135BK2	1	Handle Weldment	23	12367	2	Hose Clamp
5	10199	1	Hex Nut (1/4-20)	24	253490	1	90° Elbow Fitting
6	252297	1	90° Elbow Fitting	25	66484	1	Air Motor (4 HP; See Form No. 108171)
7	250804	2	90° Elbow Fitting	26	46626	1	Heat Exchanger Coil
8	360131	1	Tee Fitting	27	252041	1	Sealing Washer (1.5 x 1.05 x .141)
9	17565	1	Air Valve	28	18286	1	Special Washer (1-23/64 x 57/64 x 1/16 thk.)
10	10617	1	90° Elbow Fitting	29	252355	1	Straight Fitting (Torque to 80-100 in. lbs.)
11	15457	4	90° Elbow Fitting	30	13966	1	Muffler
12	360132	1	Air Valve	31	205505	1	Muffler Deflector
13	15883	3.34'	Plastic Tubing (1/4 O.D.)	32	66209	1	4-way Air Op. Valve Ass'y (See Form No. 108100)
14	212897	1	90° Elbow Fitting				
15	10177	9	Machine Screw (1/4-20 x 3/4 Lg.)				
16	12328	1	Straight Fitting (1/4 NPTF)				
17	10621	1	90° Elbow Fitting				
18	212898	1 ft.	Pressure Hose				
19	15456	1	Straight Nipple Fitting				

REMOTE CONTROL & HOSE ASSEMBLY

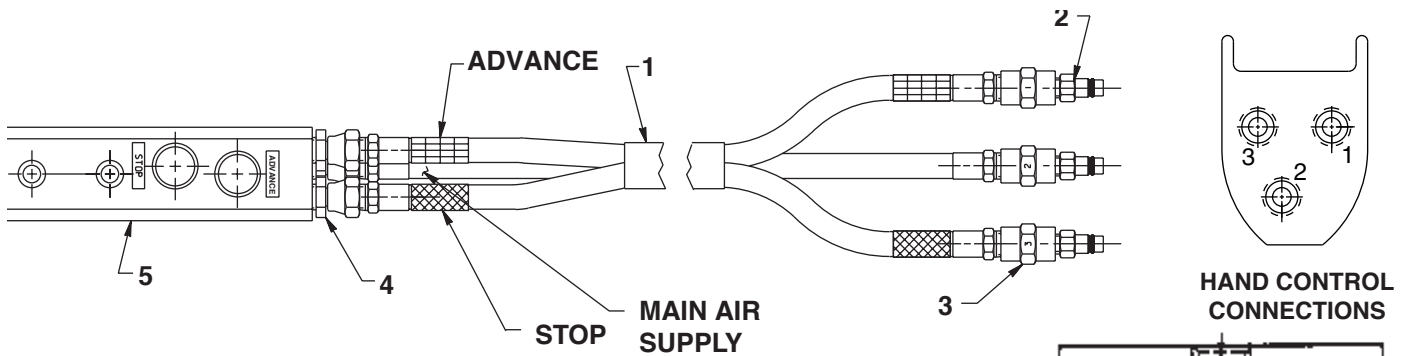

Item No.	Part No.	No. Req'd	Description
1	420096	1	Pneumatic Hose Assembly (Three Strand; NOTE: Connect hose assembly to remote control & pump as shown. Color coded or numbered ends must correspond to numbers on the remote control and pump unit.)
2	213343	3	Quick Coupler (Male)
3	18841	3	Straight Fitting
4	208218	3	Straight Fitting
5	421257	1	Air Operated Hand Control Assembly (See below)

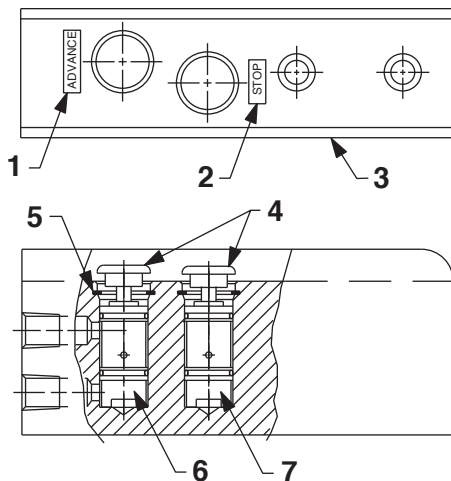
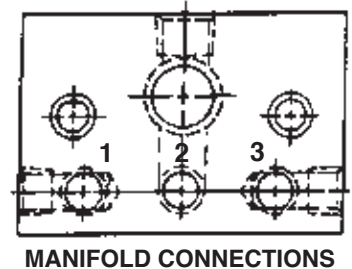

#421257 HAND CONTROL ASSEMBLY

Item No.	Part No.	No. Req'd	Description
1	29663	1	Decal (Advance)
2	203769	1	Decal (Stop)
3	421256	1	Control Valve Body
4	206105	2	Push Button
5	11033	2	Retaining Ring
6	206104	1	Valve Cartridge (Including seals)
7	252121	1	Valve Cartridge (Including seals)

GENERAL PUMP ASSEMBLY

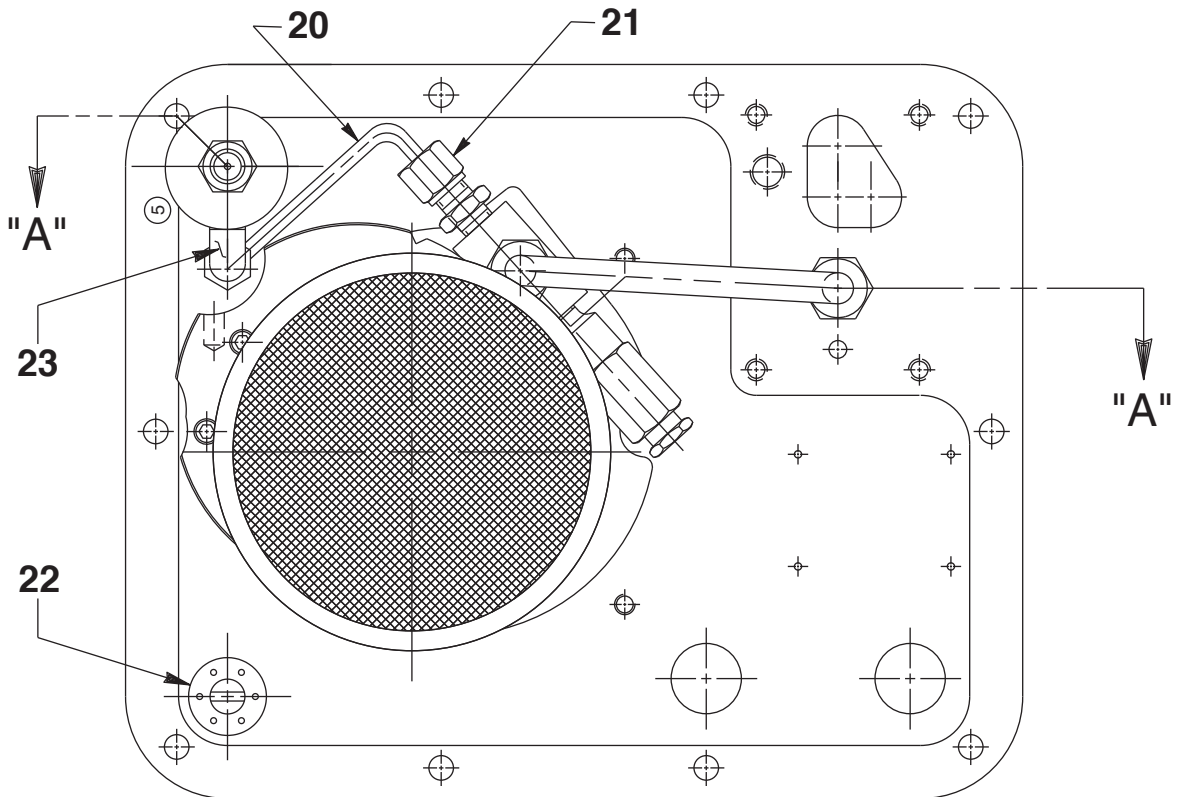
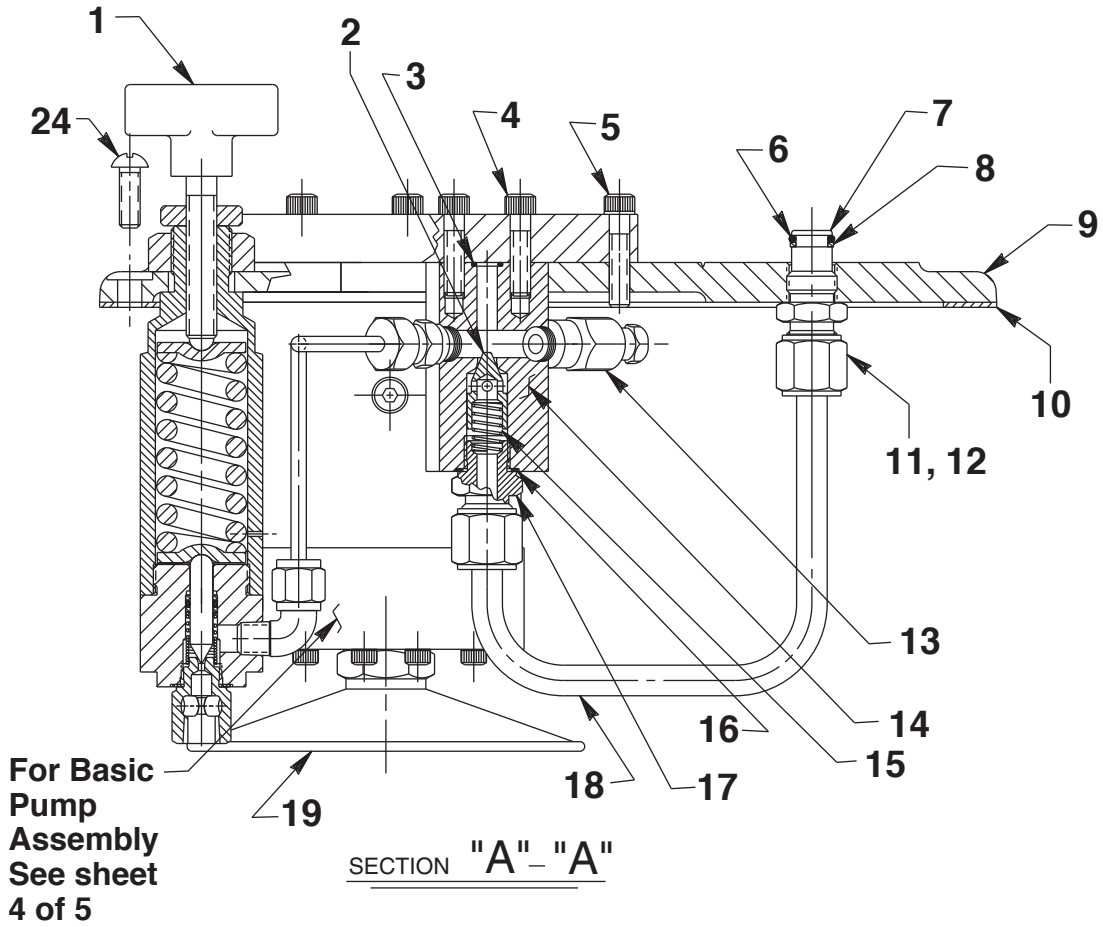

Parts List, Form No. 108179, Back sheet 3 of 5

Item No.	Part No.	No. Req'd	Description
1	421280	1	Pressure Regulator Assembly (See Form No. 101697)
2	20771	1	Poppet
3	10266	2	O-ring (1/4 x 3/8 x 1/16)
4	10015	2	Cap Screw (1/4-28 x 1" Lg.; Torque to 180 in. lbs.)
5	10016	3	Cap Screw (1/4-20 UNC X 1" Lg.)
6	10268	1	O-ring (3/8 x 1/2 x 1/16)
7	20787	1	Valve Connector
8	11863	1	PTFE Backup Washer
9	46627BK2	1	Cover
10	40164	1	Gasket
11	10430	2	Tube Sleeve (3/8)
12	10431	2	Tube Nut
13	21278	1	Relief Valve Assembly (Set at 10,100-10,700 PSI)
14	20776	1	Valve Body
15	10425	1	Compression Spring (3/8 O.D. x 3/4 Lg.)
16	10261	1	Copper Washer
17	20770	1	Connector (Torque to 40/45 ft. lbs. oiled)
18	21045	1	Oil Line
19	21345	1	Filter Assembly (Includes item #20)
20	201570	1	Pressure Control Valve Oil Line
21	14844	1	Male Connector
22	20937	1	Filler Plug
23	16177	1	90° Elbow Fitting
24	10177	9	Machine Screw (1/4-20 UNC X 3/4 Lg.)

BASIC PUMP ASSEMBLY

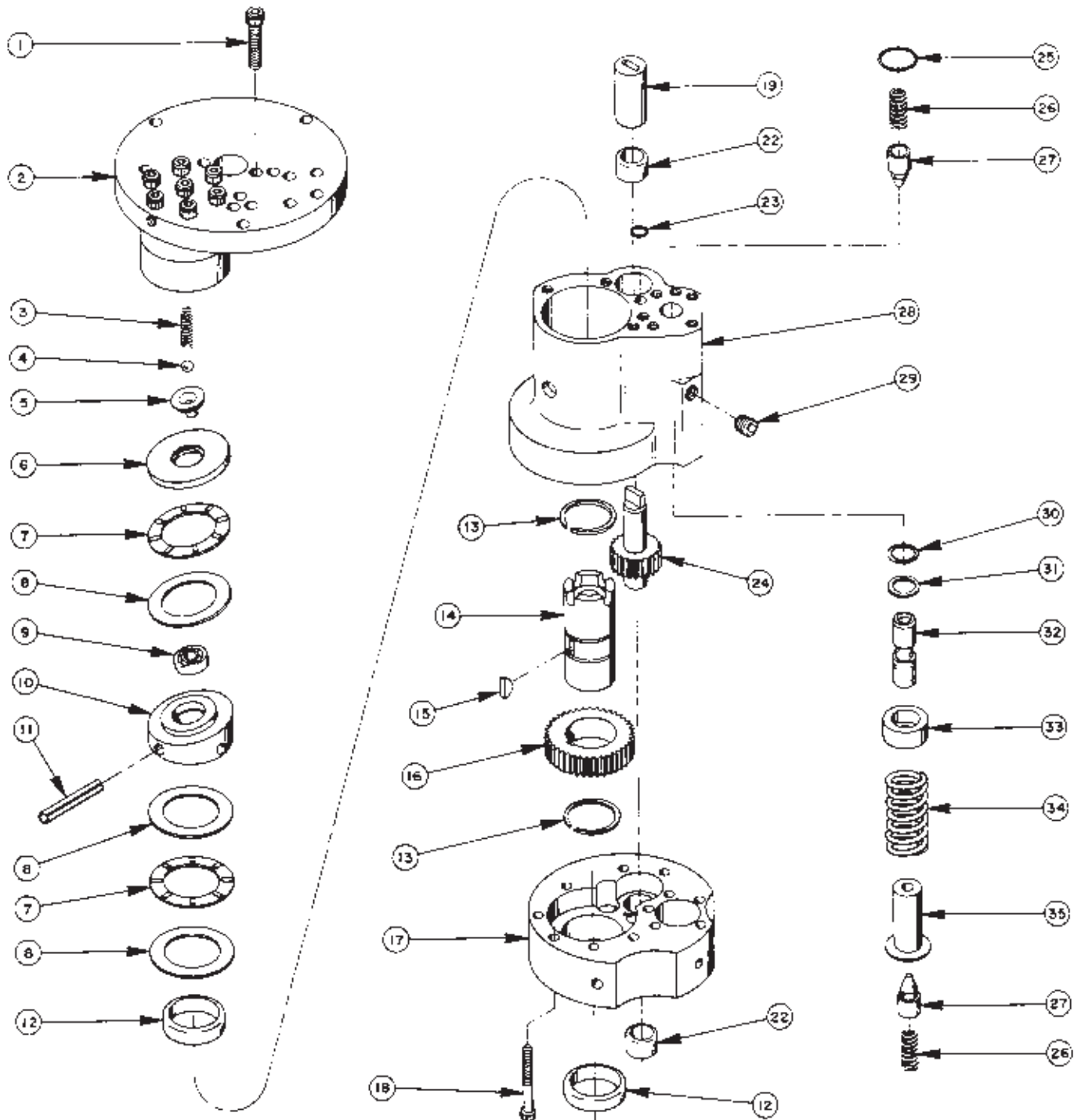

Parts List, Form No. 108179, Back sheet 4 of 5

Item No.	Part No.	No. Req'd	Description
1	10020	9	Soc. Hd. Cap Screw (1/4-20 UNC X 1-1/4 Lg.; Torque to 170-180 in. lbs.)
2	33113	1	High Pressure Pump Ass'y (See sheet 5 of 5)
3	10361	1	Compression Spring (1/4 O.D. X 1" Lg.)
4	10375	1	Steel Ball (1/4" dia.)
5	23547	1	Bearing Top Plate
6	23548	1	Top Plate
7	11228	2	Thrust Bearing
8	11813	3	Bearing Race
9	11814	1	Ball Bearing
10	23549	1	Angle Plate
11	11955	1	Roll Pin (1/4" dia. X 1-3/4 Lg.)
12	11064	2	Needle Bearing
13	11261	2	Retaining Ring
14	23556	1	Shaft
15	11821	1	Woodruff Key
16	23557	1	Gear
17	30533	1	Pump End Plate
18	10001	12	Soc. Hd. Cap Screw (#10-32 UNF X 1-3/4" Lg.; Torque to 50/60 in. lbs.)
19	252108	1	Coupling
22	11198	2	Needle Thrust Bearing (See Note below)
23	10266	1	O-ring (3/8 X 1/4 X 1/16)
24	21272	1	Drive Gear
25	10303	1	O-ring (7/8 X 3/4 X 1/16)
26	10425	2	Compression Spring (3/8 O.D. X 3/4 Lg.)
27	20771	2	Poppet
28	40120	1	Pump Body
29	10427	1	Pipe Plug (1/8" NPTF)
30	10271	1	O-ring (11/16 X 1/2 X 3/32)
31	12389	1	PTFE Backup Washer (11/16 X 1/2 X 1/16)
32	20849	1	Spool
33	23255	1	Spring Guide
34	10426	1	Compression Spring (1" O.D. X 1-13/16 Lg.)
35	23256	1	Spring Guide

NEEDLE BEARING SPECIFICATIONS

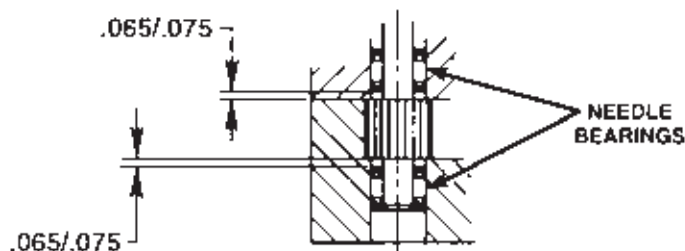

When replacing the needle bearings on the drive gear of the basic pump, the dimensions shown must be as specified.

Note: Shaded areas reflect last revision(s) made to this form.

HIGH PRESSURE PUMP ASSEMBLY

See Diagram
on Reverse
Side for
Important
Ass'y.
Information

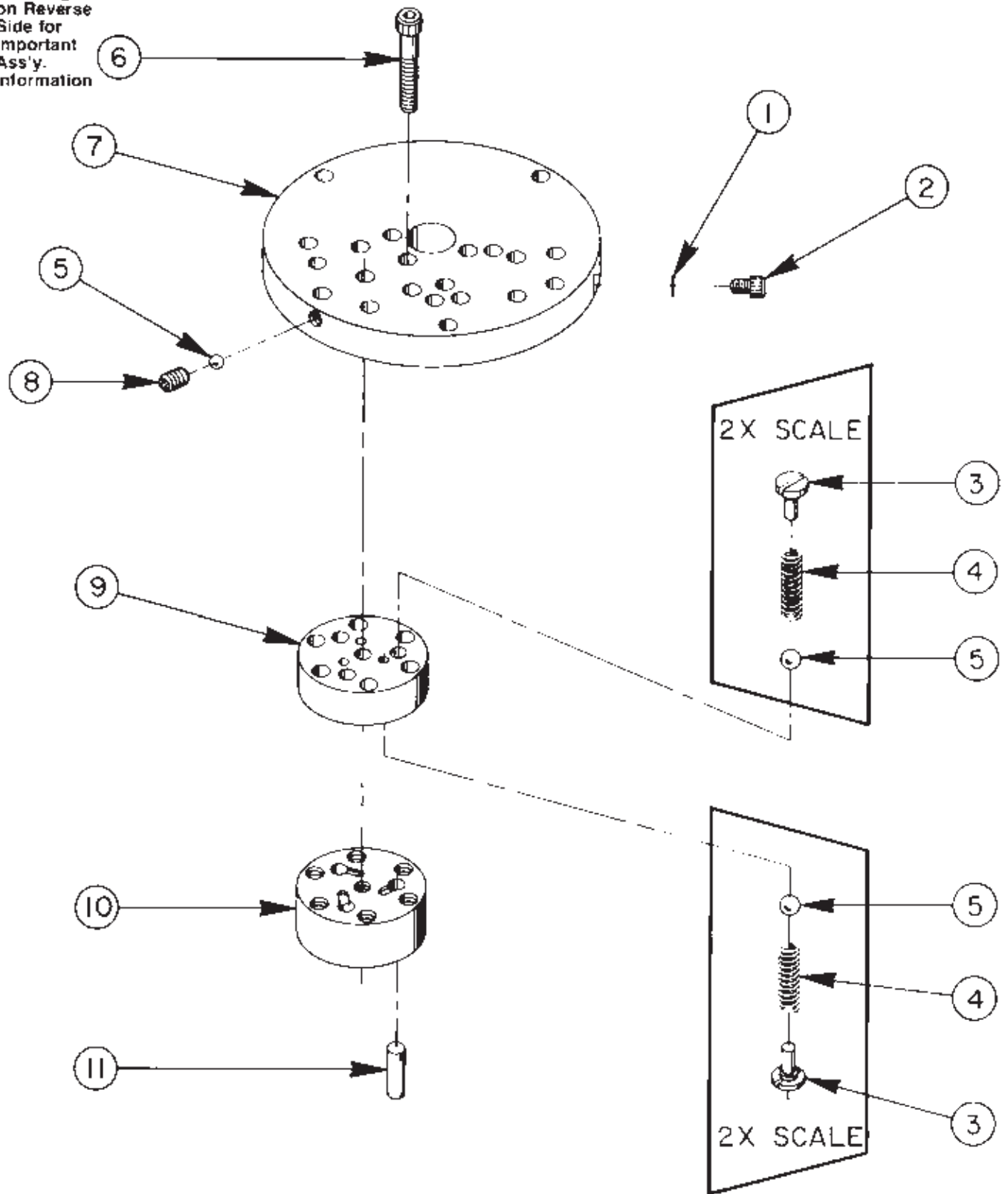

33113 PUMP ASSEMBLY
3 PISTON - 9/32 DIA.

Item No.	Part No.	No. Req'd	Description
1	10442	1	Copper Washer (3/8 X 1/4 X 1/32)
2	10002	1	Soc. Hd. Cap Screw (1/4-20 UNC X 3/8" Lg.; Torque to 140/160 in. lbs.)
3	24549	6	Valve Guide
4	10445	6	Compression Spring (5/32" O.D. X 3/4" Lg.)
5	12223	7	Steel Ball
6	10023	7	Soc. Hd. Cap Screw (1/4-20 UNF X 1-1/2" Lg.; Torque to 170/180 in. lbs.; See note below)
7	50411	1	Top Plate
8	10519	1	Soc. Set Screw (1/4-20 UNC X 3/8 Lg.; Torque to 65/70 in. lbs.)
9	40630	1	Valve Head
10	41062	1	Pump Barrel
11	21628	3	Piston

BOLT TIGHTENING SEQUENCE

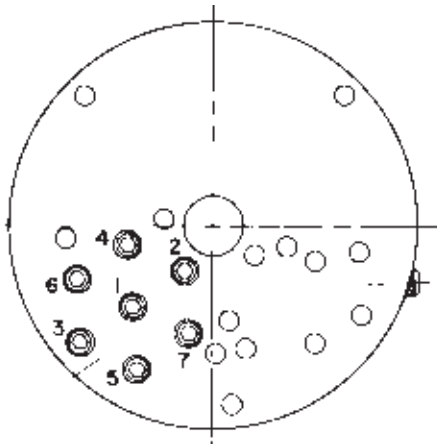

**NOTE: Assemble in sequence shown.
 Lubricate under head and on threads.
 Torque to 180 in. lbs.**