

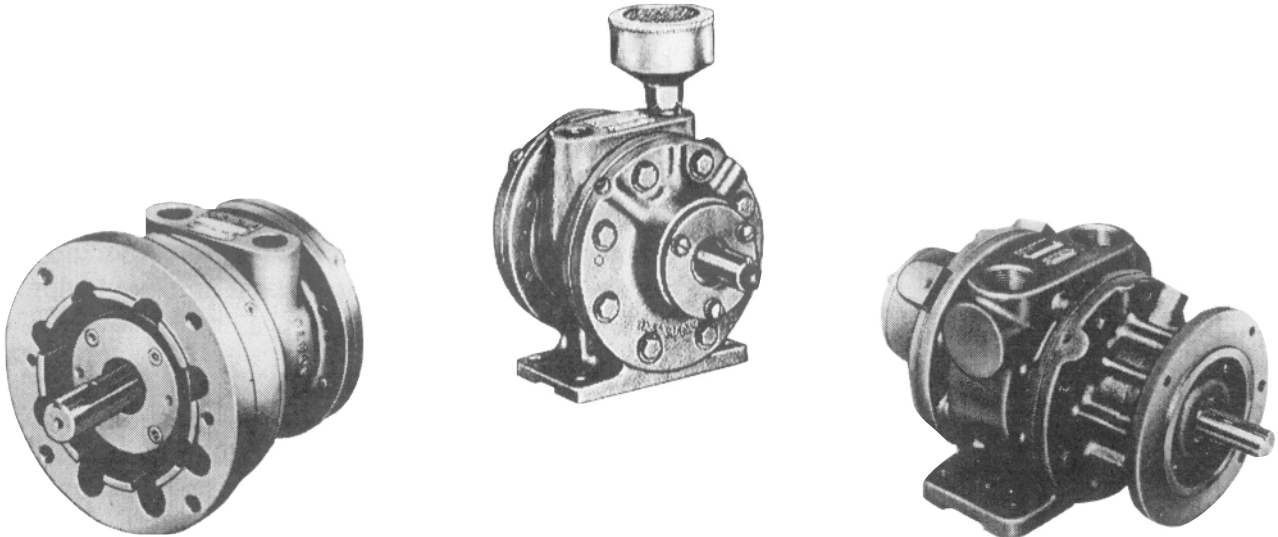

**6AM, 8AM, and 16AM  
LUBRICATED AIR MOTORS  
OPERATION & MAINTENANCE  
TECHNICAL MANUAL**



**CONTENTS:**

General Information, Installation, and Operation.....2  
Shut-Down Procedures, Servicing, and Troubleshooting Guide.....3  
6AM Series Exploded View and Parts Ordering Information.....4  
8AM Series Exploded View and Parts Ordering Information.....5  
16AM Series Exploded View and Parts Ordering Information.....6  
Gear Motor Information and Authorized Service Facilities.....7-8



**KEEP THIS DOCUMENT FOR FUTURE REFERENCE**

This is the hazard alert symbol: **⚠** When you see this symbol, be aware that personal injury or property damage is possible. The hazard is explained in the text following the symbol. Read the information carefully before proceeding.

The following is an explanation of the three different types of hazards:

- ⚠ DANGER** Severe personal injury or death will occur if hazard is ignored.
- ⚠ WARNING** Severe personal injury or death can occur if hazard is ignored.
- ⚠ CAUTION** Minor injury or property damage can occur if hazard is ignored.

**GENERAL INFORMATION**

The air motor is designed to be driven by compressed air and under no circumstances be driven with any other gases. The air motor must not be driven by fluids, particles, solids or any substance mixed with air, particularly combustible substances likely to cause explosions.

- ⚠ DANGER** Do not drive with flammable or explosive gases.
- ⚠ CAUTION** The air motor is designed for air only. Do not allow corrosive gases or particulate material to enter the motor. Water vapor, oil-based contaminants, or other liquids must be filtered out.

Ambient temperature should not exceed 121°C (250°F).

**INSTALLATION**

The muffler is shipped with the air motor, but not installed. Install a moisture trap and filter in the air line ahead of motor. For maximum efficiency, use air lines the same size or next larger size to plumb the air motor ports. A single rotation motor will operate properly in only one direction. A reversible motor will work equally in both directions. A 4-way valve which can be connected by piping to both air ports of the motor will make reversing possible. When coupling or connecting the motor to a driven member, avoid any end or side thrust on the shaft and especially **do not** hammer on the shaft itself or on the coupling or pulley you might attach.

**LUBRICATION - USE A DETERGENT SAE #10 AUTOMOTIVE ENGINE OIL (GAST PART #AD220).** An automatic air line lubricator, must be installed in the air line just ahead of the air motor.

The lubricator should be adjusted to feed one drop of oil for every 50-75 CFM of air going through the motor. Air consumption figures for various models at various speeds and airline pressures can be obtained from your local Gast representative or the factory. Lubrication is necessary for all internal moving parts and rust prevention.

Excessive moisture in the air line can cause rust formation in the motor and might also cause ice to form in the muffler due to expansion of air through the motor. The moisture problem can be improved by installing a moisture separator in the line and also by installing an aftercooler between the compressor and air receiver. The moisture problem can be corrected by drying the compressed air stream to a pressure dewpoint lower than the lowest ambient temperature along the compressed air system.

**MOUNTING THE AIR MOTOR**

- ⚠ WARNING** Beware of any exposed or movable parts. Proper guards should be in place to prevent severe personal injury or property damage.

The air motor should be mounted on a solid base plate, preferably of metal which in turn should be anchored to a shelf, the floor, or other machinery.

**OPERATION**

- ⚠ WARNING** Solid or liquid material exiting the unit can cause eye or skin damage. Keep away from air stream.
- ⚠ WARNING** Always disconnect the air supply before servicing.
- ⚠ CAUTION** Do not allow the air motor to "run free" at high speeds with no loads. Excessive internal heat build up, loss of internal clearances and rapid motor damage will result. See table below for air motor limitations.
- ⚠ WARNING** These models will exceed 85 db(A) sound level at some operating loads and speeds. Hearing protection should be worn when in close proximity to these models.

**Air Motor Performance Limits**

Motor Size	Maximum R.P.M.	Maximum Pressure psig	Maximum Torque lb.-inch	Maximum Air Consumption cfm
6AM	3000	100	115	130
8AM	2500	100	190	175
16AM	2000	100	375	280

Maximum Torque and Air Consumption can vary depending on specific operating conditions.

**STARTING**

The starting torque is less than the running torque and could vary depending on the position at which the vanes stop in relation to the air intake port. The speed and torque can be regulated by using a pressure regulator or a simple shut-off valve to obtain desired power and conserve air.

**SHUTDOWN AND STORAGE PROCEDURE**

1. Turn off air intake supply and remove plumbing.
2. Remove air motor from the connecting machinery.
3. Use clean, dry air at low pressure to "flush out" condensates, such as water.

**⚠WARNING** Solid or liquid material exiting the unit can cause eye or skin damage. Keep away from the air stream.

4. Re-lubricate the air motor with a squirt of oil in the chamber. Rotate the shaft by hand several times.
5. Plug or cap each port. The unit is now ready for storage.

**SERVICING**

If unit requires more than installation of a service kit, it is usually quickest and least expensive to send the unit in for repair.

**⚠WARNING** To prevent explosive hazard DO NOT drive this air motor with combustible gases. Injury and/or property damage can result.

**⚠WARNING** DO NOT USE KEROSENE OR OTHER COMBUSTIBLE SOLVENTS.

**⚠WARNING** Eye protection is REQUIRED. Keep face away from exhaust port and do not flush unit with flammable solvent.

**⚠WARNING** Foreign material exiting the air motor can be hazardous.

**⚠CAUTION** Do not drive the air motor in excess of the recommended speeds.

If the motor is sluggish or inefficient, try flushing with solvent\*.

-To flush a unit, disconnect air line and muffler and add several teaspoons or spray solvent directly into the motor.

-Rotate the shaft by hand in both directions for a few minutes, reconnect the air line and slowly apply pressure until there is no trace of solvent in exhaust air.

-Flush unit in a well ventilated area.

-Re-lubricate the motor with a squirt of oil in the chamber.

**NOTE:** If the vanes need replacing or foreign materials are present in motor chamber, an experienced mechanic may remove the end plate opposite the drive shaft end. **DO NOT PRY WITH A SCREW-DRIVER.** It will dent the surface of the plate and body causing leaks.

A puller tool should be used which will remove the endplate while maintaining the position of the shaft. New vanes should have the edge with the corners cut on angle or the notched edge (if reversible) towards the bottom of the vane slot.

\*Recommended solvent for air motors and lubricated pumps is Gast Flushing solvent part # AH255B , Loctite Safety Solvent, or Inhibisol Safety Solvent.

**Air Motor Clearance Chart**

<b>US/IMPERIAL (IN) / METRIC (mm)</b>		
Model	Total End Clearance	Top Clearance
6AM	0.0035 / 0.0889	0.0015 / 0.0381
8AM	0.0048 / 0.1219	0.0015 / 0.0381
16AM	0.0060 / 0.1524	0.0015 / 0.0381

**TROUBLESHOOTING GUIDE**

Reason	Low Torque	Low Speed	Won't Run At All	Runs Hot	Runs Good Then Slows Down
Dirt, foreign material	X	X	X		
Internal rust	X	X	X		
Misalignment	X	X	X	X	X
Insufficient air pressure	X	X			
Too small of airline		X			
Restricted exhaust		X			X
Poor lubrication	X	X	X	X	
Jammed machine	X	X	X		X
Compressor too small		X			X
Compressor too far from unit		X			X

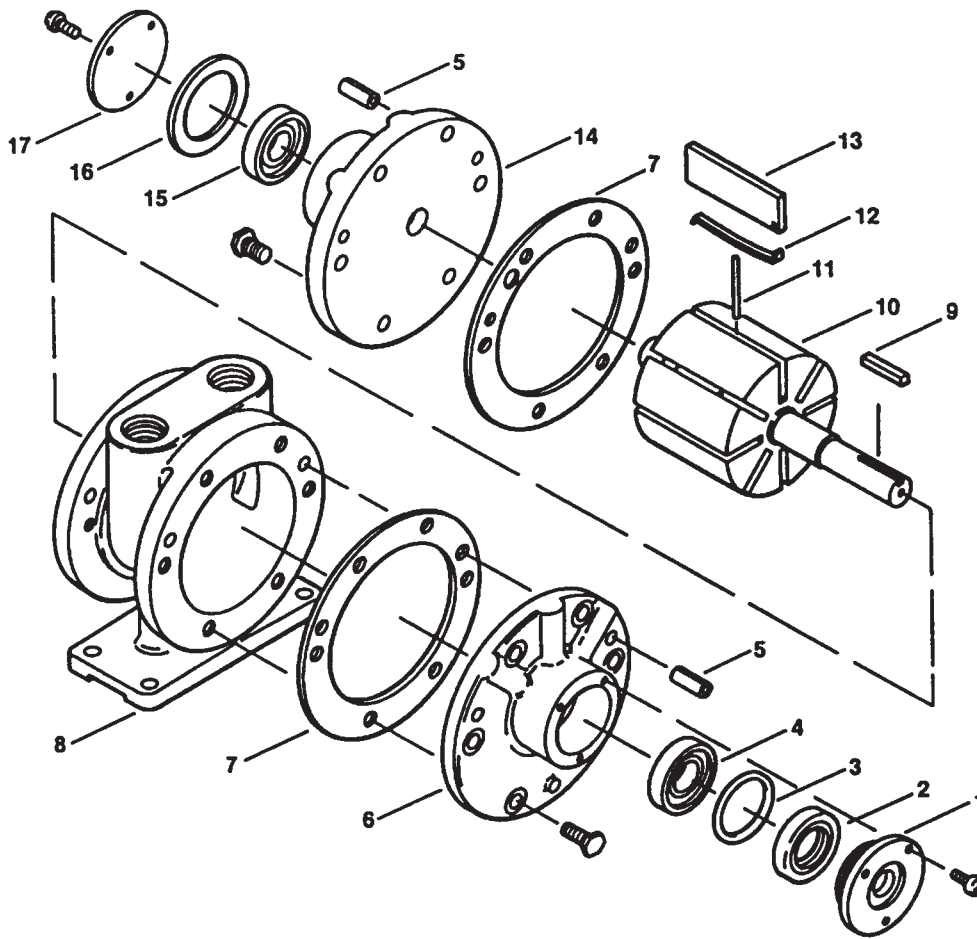

Ref. No.	Description	Part Qty	6AM-FRV-5A	6AM-NRV-7A	6AM-NRV-22A NEMA	6AM-FRV-23A	6AM-ARV-54	6AM-ARV-55	6AM-NRV-11A
1	End Cap, Drive End	1	AD642A	AD642A	AD642A	AD642A	AC998	AC998	AD642A
•2	Shaft Seal	1	AC849A	AC849A	AC849A	AC849A	AK423	AK423	AC849A
•3	O-Ring	1	AD649	AD649	AD649	AD649	AC989	AC989	AD649
•4	Bearing, Drive End	1	AD638A	AD638A	AD638A	AD638A	AG894B	AC894B	AD638A
5	Dowel Pin	4	AB162	AB162	AB162C	AB162	AB162C	AB162C	AB162C
6	End Plate, Drive	1	AD651	AD666	AD667	AD651	AK535	AK535	AD667
•7	Body Gasket	2	AD641	AD641	AD641	AD641	AD641	AD641	AD641
8	Body	1	AD650A	AD665	AD665	AD650A	AD665D	AD665D	AD665
9	Key	1	AB136	AB136	AB136	AB136	AK422	AK422	AB136
10	Rotor Assembly	1	AD652	AD652	AC398	AC779	AD648E	AD648D	AD648
•11	Push Pin	2	AD655A	AD655A	(4) AD655A	(4)AD655A	AD655A	(4) AD655A	AD655A
•12	Vane, Spring	4	AD692	AD692	(8) AD692	(8) AD692	AD692	(8) AD692	AD692
•13	Vane	4	AD691	AD691	(8) AD691	(8) AD691	AD691	(8) AD691	AD691
14	End Plate, Dead	1	AD651	AD651	AD651	AD651	AD651	AD651	AD651
•15	Bearing, Dead End	1	AB519	AB519	AB519	AB519	AB519	AB519	AB519
•16	End Cap, Gasket	1	AD644	AD644	AD644	AD644	AD644	AD644	AD644
17	End Cap, Dead End	1	AD643	AD643	AD643	AD643	AD643	AD643	AD643
	Muffler Assembly	1	AC990	AC990	AC990	AC990	AC990	AC990	AC990
	Felt	1	AC993	AC993	AC993	AC993	AC993	AC993	AC993
	Service Kit	1	K208	K208	K281	K281	K281A	K281B	K208

• Denotes Parts included in the service kit.

Parts listed are for stock model units. For specific OEM models consult the factory. When ordering parts please provide full model and serial number.

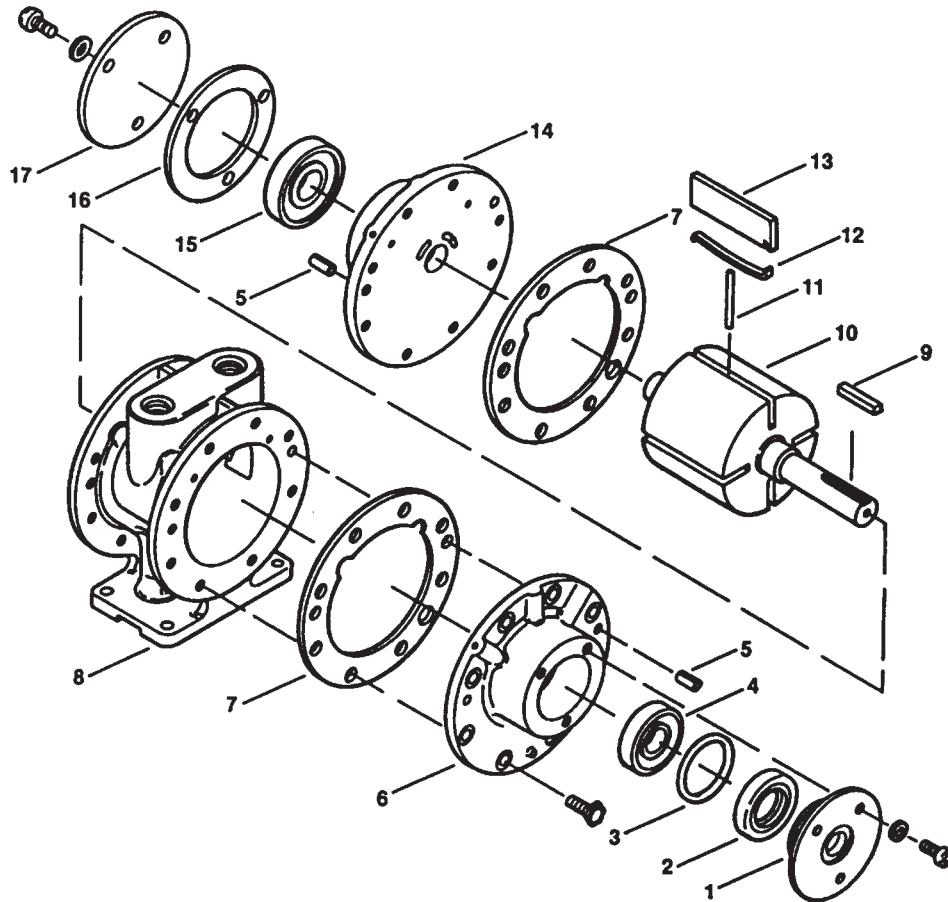

Ref. No.	Description	Part Qty	METRIC							
			8AM-FRV-2B	8AM-NRV-5B	8AM-NRV-28A	8AM-FRV-30A	8AM-NRV-32A	8AM-NRV-42A	8AM-ARV-70	8AM-ARV-71
1	End Cap, Drive End	1	AC835A	AC835A	AC988	AC835A	AC988	AC835A	AC988	AC988
•2	Shaft Seal	1	AC839	AC839	AB936	AC839	AB936	AC839	AK420	AK420
•3	O-Ring	1	AC808	AC808	AC989	AC808	AC989	AC808	AC989	AC989
•4	Bearing, Drive End	1	AA735B	AA735B	AB927	AA735B	AB927	AA735B	AB927	AB927
5	Dowel Pin	4	AB162	AB162	AB162	AB162	AB162	AB162	AB162	AB162
6	End Plate, Drive	2	AC964	AC963	AC965	AC964	AC965	AC963	AK421	AK421
•7	Body Gasket	2	AC888	AC888	AC888	AC888	AC888	AC888	AC888	AC888
8	Body	1	AC877A	AC878C	AC878C	AC877A	AC878C	AC878C	AC878G	AC878G
9	Key	1	AB136D	AB136D	AB136D	AB136D	AB136D	AB136D	AK668	AK668
10	Rotor Assembly	1	AC977	AC977	AC986	AC977A	AC986A	AC977A	AC986D	AC986C
•11	Push Pin	2	AC879	AC879	AC879	(4)AC879	(4)AC879	(4)AC879	AC879	(4)AC879
•12	Vane, Spring	4	AC817	AC817	AC817	(8)AC817	(8)AC817	(8)AC817	AC817	(8)AC817
•13	Vane	4	AC816	AC816	AC816	(8)AC816	(8)AC816	(8)AC816	AC816	(8)AC816
14	End Plate, Dead	1	AC964	AC964	AC964	AC964	AC964	AC964	AC964	AC964
•15	Bearing, Dead End	1	AC894B	AC894B	AC894B	AC894B	AC894B	AC894B	AC894B	AC894B
•16	End Cap, Gasket	1	AC837	AC837	AC837	AC837	AC837	AC837	AC837	AC837
17	End Cap, Dead End	1	AC836	AC836	AC836	AC836	AC836	AC836	AC836	AC836
	Muffler Assembly	1	AC990	AC990	AC990	AC990	AC990	AC990	AC990	AC990
	Felt	1	AC993	AC993	AC993	AC993	AC993	AC993	AC993	AC993
	Service Kit	1	K210	K210	K211	K283	K282	K283	K282A	K282B

• Denotes Parts included in the service kit.

Parts listed are for stock model units. For specific OEM models consult the factory. When ordering parts please provide full model and serial number.

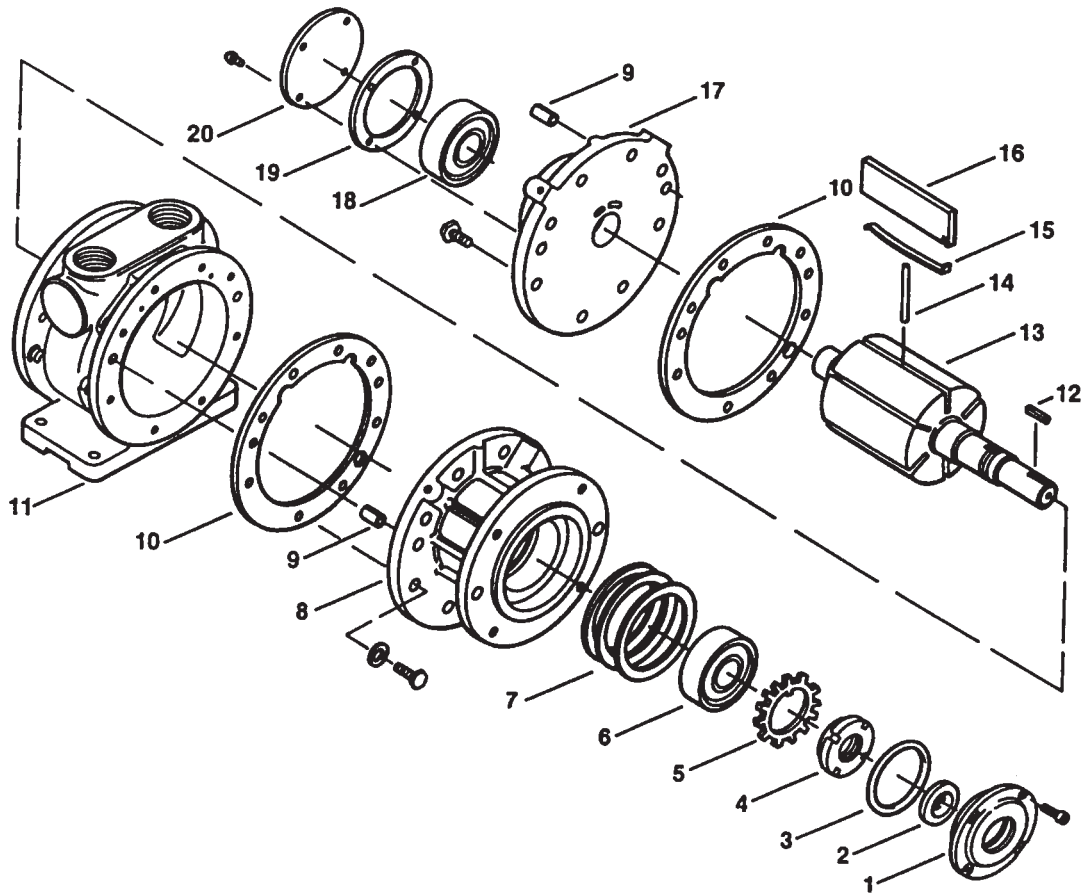

Ref. No.	DESCRIPTION	Part Qty	16AM-FCC-1	16AM-FRV-2	16AM-FRV-13
1	End Cap, Drive	1	AD816	AD816	AD816
•2	Seal	1	AC627	AC627	AC627
•3	O-Ring	1	AD823	AD823	AD823
4	Locknut	1	AD784	AD784	AD784
•5	Lockwasher	1	AD712	AD712	AD712
•6	Bearing, Drive End	1	AB777A	AB777A	AB777A
7	Spacer		AD786	AD786	AD786
8	End Plate, Drive	1	AD771A	AD820A	AC323
9	Dowel Pin	4	AB162A	AB162A	AB162A
•10	Body Spacer Gasket	2	AD788	AD788	AD788
11	Body	1	AD770	AD819	AD819
12	Drive Key	1	AC628	AC628	AB136D
13	Rotor Assembly	1	AD775	AD794	AE807
•14	Push Pin	3		AD822	AD822
•15	Vane Spring	6		AD796A	AD796A
•16	Vane	6	AD781	AD795	AD795
17	End Plate, Dead	1	AD773A	AD821A	AD821A
•18	Bearing, Dead End	1	AD802	AD802	AD802
19	End Cap Gasket	1	AG406	AG406	AG406
20	End Cap, Dead End	1	AG405	AG405	AD405
	Service Kit	1	K212	K213	K213

• Denotes Parts included in the service kit.

Parts listed are for stock model units. For specific OEM models consult the factory.

When ordering parts please provide full model and serial number.

# OPERATING AND MAINTENANCE INSTRUCTIONS

# GR11, GR20, GR25, AND WORM TYPE GEAR REDUCERS

**IMPORTANT INFORMATION:** **⚠ WARNING** Gast air-powered garmotors are not self locking. In applications where a brake is required for safety, in case of air pressure failure, contact your Distributor. Mount horizontal or shaft down. **DO NOT MOUNT WITH SHAFT UP.**

## GR11 GEAR REDUCER SPECIFICATIONS:

**Speed Range:** (Reducer output shaft)  
33.3 RPM to 400 RPM.

**Gear Reduction:** 15:1

**Max. allowable end thrust with 0 overhung load is 100 lbs. (45,4 kg).**

**Max. allowable overhung load with 0 end thrust from 100 lbs. (45,4 kg) at 333 rpm to 200 lbs. (90,8 kg) at 33.3 rpm.**

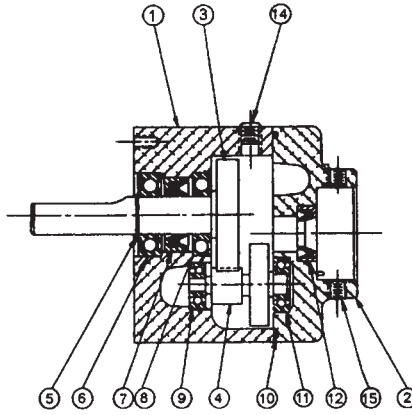

**GR11 PARTS ORDERING INFORMATION**

Ref. No.	Description	Part Qty	Part Number
1	Gear Housing	1	AC737
2	Cover, Gear Housing	1	AC736
3	Gear Shaft	1	AC739
4	Cluster Gear	1	AC738
5	Snap Ring	1	AE189
6	Bearing	1	AE196A
7	Seal	1	AA517A
8	Bearing	1	AA498
9	Bearing	1	AE195
10	O-Ring	1	AD823
11	Bearing	1	AE197
12	Seal	1	AA623D
13	Screws	4	BB542
14	Pipe Plug	2	BA500
15	Set Screw	2	BB626
16	Dowel Pin (not shown)	2	AE882

## GR20 GEAR REDUCER SPECIFICATIONS:

**Speed Range:** (Reducer output shaft)  
30 RPM to 300 RPM.

**Gear Reduction:** 10:1

**Max. allowable end thrust with 0 overhung load ranges from 200 lbs. (90 kg) at 300 rpm, to 800 lbs. (362 kg) at 30 rpm.**

**Max. allowable overhung load with 0 end thrust ranges from 200 lbs. (90 kg) at 300 rpm, to 600 lbs. (272 kg) at 30 rpm.**

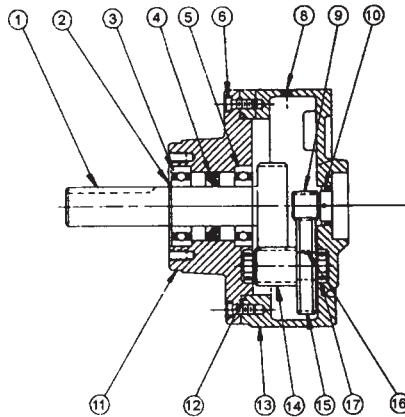

**GR20 PARTS ORDERING INFORMATION**

Ref. No.	Description	Part Qty	Part Number
1	Gear Shaft, Output	1	AE848
2	Retaining Ring	1	AE853
3	Bearing	1	AE858
4	Oil Seal	1	AE852
5	Bearing	1	AE857
6	Screw	6	BB652
	Dowel Pin (not shown)	2	AF482
8	Magnetic Drain Plug	2	AH471
9	Gear, Input	1	AA294
10	Oil Seal	1	AE851
11	Housing Cover	1	AE849
12	O-Ring	1	AE854
13	Gear Housing	1	AE850
14	Shaft, Gear	1	AE845
15	Gear, Intermediate	1	AE846
16	Key	1	AE855
17	Bearing	2	AG549

## GR25 GEAR REDUCER SPECIFICATIONS:

**Speed Range:** (Reducer output shaft)  
20 RPM to 200 RPM.

**Gear Reduction:** 15:1

**Max. allowable end thrust with 0 overhung load ranges from 250 lbs. (91 kg) at 200 rpm to 800 lbs. (363 kg) at 20 rpm.**

**Max. allowable overhung load with 0 end thrust ranges from 200 lbs. (90 kg) at 200 rpm to 600 lbs. (272 kg) at 20 rpm.**

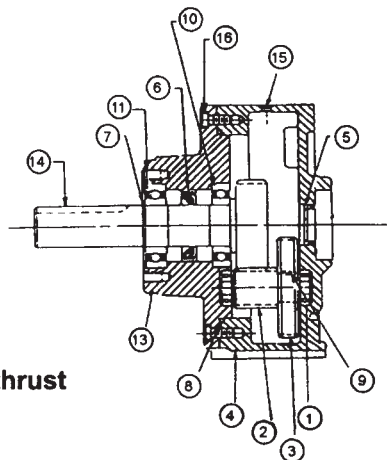

**GR25 PARTS ORDERING INFORMATION**

Ref. No.	Description	Part Qty	Part Number
1	Bearing	2	AC206A
2	Shaft Gear	1	AE845
3	Gear Intermediate	1	AE846
4	Gear Housing	1	AE850
5	Seal	1	AE851
6	Seal	1	AE852
7	Retaining Ring	1	AE853
8	O-Ring	1	AE854
9	Key	1	AE855
10	Bearing	1	AE857
11	Bearing	1	AE858
	Dowel Pin (not shown)	2	AF482
13	Housing Cover	1	AF278
14	Gear Shaft Output	1	AH279
15	Magnetic Drain Plug	2	AH471
16	Screw	6	BB652

## WORM GEAR REDUCER SERIES A, B, C, D, E, & F

The following instructions apply to standard Worm Gear Reducers. When ordering parts or requesting information specify all information stamped on the reducer nameplate. The nameplate will also identify the type of lubricant to be used. For all Worm Gear Reducers, the Air Motor must be mounted so that intake and exhaust piping is at a 90° angle to the centerline of the Reducer Output Shaft.

### TO CHANGE OUTPUT SHAFT DIRECTION

To change the hand of a unit from left hand to right hand, or vice versa, the following instructions apply:

1. Remove drain plug and drain oil from unit.
2. Remove end cover and seal cage cap screws; then while supporting output shaft remove end cover and shims from the unit
3. Remove output shaft and seal cage together from extension side. NOTE: Keep shims with their respective seal cage and end cover.
4. Insert seal cage, shims and sub-assembly into the housing from the side opposite from which they were removed. Insert seal cage cap screws and tighten with light pressure.
5. Assemble end cover and shims. Insert end cover cap screws and tighten with light pressure.
6. Turn high speed shaft in both directions to see that gear train is running freely.
7. Cross tighten seal cage and end cover cap screws to torques listed below.

### CAPSCREW TIGHTENING TORQUE

Capscrew Diameter	1/4 - 20 UNC	5/16 - 18 UNC	3/8 - 16 UNC
Torque (in. lbs.) Dry	96	204	360

Reducer Part No.	USE WITH AIR MOTOR MODEL	RATIO	LOCATION OF OUTPUT SHAFT
AG803	4AM	20:1	Std. Location
AG805	4AM	40:1	Std. Location
AG807	4AM	60:1	Std. Location
AG809	6AM	10:1	Std. Location
AG811	6AM	20:1	Std. Location
AG816	8AM	20:1	Std. Location

## AUTHORIZED SERVICE FACILITIES

Gast Manufacturing Corp  
2300 Highway M-139  
Benton Harbor, MI 49022  
TEL: 616-926-6171  
FAX: 616-927-0808

Gast Manufacturing Corp  
505 Washington Ave  
Carlstadt, NJ 07072  
TEL: 201-933-8484  
FAX: 201-933-5545

Brenner Fiedler & Assoc.  
13824 Bentley Place  
Cerritos, CA 90701  
TEL: 800-843-5558  
TEL: 310-404-2721  
FAX: 310-404-7975

Gast Manufacturing Co., Ltd  
Beech House, Knaves Beech  
Business Centre, Loudwater  
High Wycombe, Bucks HP 10 9SD  
England  
TEL: 44 628 532600  
FAX: 44 628 532470

Wainbee Limited  
215 Brunswick Blvd.  
Pointe Claire, Quebec  
Canada H9R 4R7  
TEL: 514-697-8810  
FAX: 514-697-3070

Wainbee Limited  
5789 Coopers Avenue  
Mississauga, Ontario  
Canada L4Z 3S6  
TEL: 416-213-7202  
FAX: 416-213-7207

Japan Machinery Co. Ltd.  
Central PO Box 1451  
Tokyo, 100-91 Japan  
TEL: 81-3-3573-5421  
FAX: 81-3-3571-7865  
or: 81-3-3571-7896

NOTE: General Correspondence  
should be sent to—  
Gast Manufacturing Corp.  
P O Box 97  
Benton Harbor, MI 49022-0097